

Driving Range Tee Box Dispenser

BID DATE: April 12, 2021

BID TIME: 10:30AM

PREPARED BY:

HOFFMAN ESTATES PARK DISTRICT
1685 W. Higgins Road
Hoffman Estates IL 60169-2998
Telephone: (847) 885-7500
Facsimile: (847) 885-7523

HOFFMAN ESTATES PARK DISTRICT

TABLE OF CONTENTS

- ❖ Invitation to Bidders
- ❖ Instructions to Bidders
- ❖ Supplementary Conditions
- ❖ Specification
- ❖ Proposal
 - ◆ Bid Proposal Form
 - ◆ Bid Certification Form
 - ◆ Contract Compliance attachment
 - ◆ Reference list
 - ◆ Certifications

March 19, 2021

Dear Bidder:

Enclosed you will find the plans, specifications and bidding materials for **Driving Range Tee Box Dispenser**. All pertinent information is included in the attached package. Please copy your proposal and retain one copy for your records.

I look forward to reviewing your bid proposal and working together with you on these projects. Should you have any questions or comments please contact me at (847) 285-5465.

Sincerely,

Dustin Hugen

Dustin Hugen
Director of Parks, Planning & Maintenance

INVITATION TO BID

Sealed bids for **Driving Range Tee Box Dispensers** will be received by the Hoffman Estates Park District at our office; 1685 West Higgins Road, Hoffman Estates, Illinois 60169 until **exactly 10:30 A.M., April 12, 2021**, and then publicly opened and read. Bids submitted after the closing time will be returned unopened.

The Hoffman Estates Park District Board of Commissioners will make final award.

Proposals shall be submitted on the attached Quotation Form and returned in sealed envelope. No bidder may withdraw his proposal after the hour set for the opening thereof, or before award of the Contract, unless said award is delayed for a period exceeding thirty (30) calendar days.

The Hoffman Estates Park District requires all bidders to comply with all provisions of the Park District Prevailing Wage Ordinance **O18-005**. This ordinance specifies that no less than the general prevailing rate of wages as found by the Park District or Department of Labor or determined by a court on review shall be paid each draft type of worker or mechanic needed to execute the contract or perform the work.

The Hoffman Estates Park District may reject any or all of the bids on any basis and without disclosure of a reason. The failure to make such a disclosure shall not result in accrual of any right, claim, or cause of action by an unsuccessful Bidder against the Hoffman Estates Park District.

Bid results and the award of the bid will be published on the Hoffman Estates Park District website www.heparks.org under General Information/Bid Information.

Sincerely,

Dustin Hugen

Dustin Hugen
Director of Parks, Planning & Maintenance

HOFFMAN ESTATES PARK DISTRICT

INSTRUCTIONS TO BIDDERS

1. Identification of Project

The official name and location of the project shall henceforth be known as:

Driving Range Tee Box Dispensers

The official name and address of the project owner shall henceforth be known as:

HOFFMAN ESTATES PARK DISTRICT
1685 West Higgins Road
Hoffman Estates, IL 60169-2998

Bid Opening: April 12th, 2021

Committee Approval: **April 20th, 2021**

Board Approval: **April 27th, 2021**

Contract Awarded: **April 30th, 2021**

Commencement of Work: Commencement of paperwork shall begin immediately upon notification of award.

2. Contract Documents

The Notice to Bidders, the Instructions to Bidders, the Drawings, the A.I.A. General Condition (by referral) the Supplementary Conditions, Specifications, the Supplied Proposal Form. The accepted Bid Sheet and certification and the Owner's Purchase Order comprise the Contract Documents.

Copies of these documents can be obtained in person from the office of the Hoffman Estates Park District, 1685 W. Higgins Road, Hoffman Estates IL 60169-2998.

3. Explanation to Bidders

Any explanation desired by a bidder regarding the meaning or interpretation of the invitation for bids, drawings, specifications, etc., must be requested in writing and with sufficient time allowed for a reply to reach bidders before the submission of their bids.

Any interpretation made will be in the form of an amendment of the invitation for bids, drawings, specifications, etc., and will be furnished to all prospective bidders. Its receipt by the bidder must be acknowledged in the space provided on the Bid Form or by letter or telegram received before the time

set for opening of bids. Oral explanations or instructions given before the award of the contract will not be binding.

4. Conditions Affecting the Work

Bidders should visit the site and take such other steps as may be reasonably necessary to ascertain the nature and location of the Work, the general and local conditions, which can affect the Work or the cost thereof. Failure to do so will not relieve bidders from responsibility for estimating properly the difficulty or cost of successfully performing the Work.

5. Bid Guarantee, Bonds and Required Paperwork - *Not Required*

- A. A Bid Guarantee, five percent (5%), is required by the invitation for bids. Failure to furnish a Bid Guarantee in the proper form and amount, by the time set for opening of bids, may be cause for rejection of the bid, in the absolute discretion of the Owner.
- B. The Bid Guarantee shall be in the form of a bid bond, postal money order, certified check, or cashier's check made payable to the Owner. Bid guarantees, other than those stated, will be returned (a) to unsuccessful bidders as soon as practicable after the award of the job; and (b) to the successful bidder upon execution of such further contractual documents and bonds as may be required by the bid as accepted.

6. Preparation and Submission of Bids

Before submitting proposal, each bidder shall carefully examine all documents pertaining to the Work and visit the sites to verify conditions under which Work will be performed.

Submission of bid will be considered presumptive evidence that the Bidder has visited the site and is conversant with local facilities and difficulties, the requirements of the documents and of pertinent State or Local Codes, State of Labor and Material Markets, and has made due allowance in his bid for all contingencies. Include in bid all costs of labor, material, equipment, allowance, fees, permits, guarantees, applicable taxes (sales tax does not apply), insurance and contingencies, with overhead and profit necessary to produce a completed project, or to complete those portions of the Work necessary to produce a completed project, or to complete those portions of the Work covered by the specifications on which proposal is made, including all trades, without further cost to the Owner. Obtain all permits and arrange for all inspections. Pay all fees and costs incurred.

No compensation will be allowed by reason of any difficulties which the Bidder could have discovered reasonably, prior to bidding.

All proposals must be made upon the Proposal Form furnished by the Owner attached hereto and should give the amounts bid for work, in numbers, and must be signed and acknowledged by the contractor. In order to insure consideration, the Proposal should be enclosed in an envelope marked "Bid Proposal for Hoffman Estates Park District –**Driving Range Tee Box Dispensers** to be received until **10:30 A.M., April 12, 2021** showing the return address of the sender and addressed to: Hoffman Estates Park District, 1685 W. Higgins Road, Hoffman Estates, Illinois 60169. Bids must be sealed,

marked and addressed as directed above. Failure to do so may result in a premature opening of, or a failure to open, such bid.

The proposal submitted must not contain erasures, inter-lineations, or other corrections unless each correction is suitably authenticated by affixing in the margin immediately opposite the correction the surname or surnames of the person or persons signing the bid.

Modifications of bids already submitted will be considered if received at the office designated in the invitation for bids by the time set for opening of bids. Telegraphic modifications will be considered, but should not reveal the amount of the original or revised bid. Unless called for, alternate bids will not be considered.

7. Prices

The prices are to include the furnishing of all materials, equipment, tools, insurance, bonds, warranties, and all other facilities, and the performance of all labor and services necessary for the proper completion of the Work except as may be otherwise expressly provided in the Contract Documents.

8. Time Schedule

The timely execution of any project is extremely important. As this work's timeliness will have a direct effect with other trade components and ultimately on the project's completion. An important factor in evaluating the bids and awarding the contract is this work's timeliness which will have a direct effect on subsequent trade or Contracts and the ultimate completion of the Project. The successful bidder will have to acknowledge that his price and proposed work will be completed according to the proposed schedule provided as part of this bid process.

9. Late Bids and Modifications or Withdrawals

Bids and modifications or withdrawals thereof received at the office designated in the invitation for bids after the exact time set for opening of bids will not be considered.

10. Withdrawal of Bids

Bids may be withdrawn by written or telegraphic request received from bidders prior to the time set for opening of bids.

11. Public Opening of Bids

Bids will be publicly opened at the time set for opening in the invitation for bids. Their content will be made public for the information of bidders and others interested, who may be present either in person or by representative.

12. Award of Contract

- A. Award of Contract will be made to the lowest responsible bidder, as determined by the Board of Commissioners of the Hoffman Estates Park District, whose bid conforms to the invitation for bid.
- B. The Board of Park Commissioners may reject any or all of the bids on any basis and without disclosure of a reason. The failure to make such a disclosure shall not result in accrual of any right, claim, or cause of action by any unsuccessful bidder against the Hoffman Estates Park District.

13. Authorization to Proceed and Insurance

The accepted bidder shall be issued a Purchase Order from the Owner as authorization to proceed. The Bidder will provide the Owner with a Labor and Material Payment Bond, Performance Bond, and copies of Workman's Compensation and Public Liability Insurance Policies or certificates therefor, within ten (10) calendar days of the "Written Notice to proceed" and prior to the commencement of the work. From this point on, the Bidder will be known as the Contractor.

14. Postponement of Date for Opening Proposals

The Owner reserves the right to postpone the date of presentation and opening of proposals and will give telegraphic notice of any such postponement to each interested party.

SPECIFICATIONS
SUPPLEMENTARY CONDITIONS

SECTION I – GENERAL

1. **Application**

The General Conditions and Supplementary General Conditions shall be used in conjunction with and are a part of any and all Sections of the Specifications and all Contracts and Subcontracts that may be made for the completion of the work in all its parts as identified and described in the Contract Documents.

2. **Definitions**

Owner: The Hoffman Estates Park District, Board of Commissioners, Staff and its appointed Owner's Representative.

Contractor: A firm, corporation or individual with whom the Owner makes a direct Contract for the construction of all or any portion of the work.

Engineer: The authorized Representative of the Owner.

The words "approve", "equal to", "as directed", etc., are interpreted and will be taken to mean "to the satisfaction of the Owner." Samples shall be submitted and approvals shall be requested in ample time to avoid any delays should resubmission of an item be necessary.

3. **Contract Documents**

The Contract Documents shall consist of Invitation and Instructions to Bidders; the proposal, the Owner's Purchase Order, the Drawings, the Supplementary Conditions and the Specifications.

4. **Bonds**

With proposal, and attached thereto, each Bidder shall furnish Bid Security payable to the Owner in the amount of 5% of bid.

5. **Payment**

Final Payment will be made only after the delivery and acceptance of the equipment in conformance with the plans and specification and upon proper invoicing along with all waivers, sworn statements, guarantee statements, and other documents set forth in the Contract Documents. Final payment will be made approximately thirty (30) days after invoicing.

6. **Preparation of Bids**

Before submitting proposal, each bidder shall examine carefully all documents pertaining to the work and visit the sites to verify conditions under which work will be performed.

Submission of bid will be considered presumptive evidence that the Bidder has visited the site and is conversant with local facilities and difficulties, the requirements of the documents and of pertinent State, County or Local Codes, State of Labor and Material Markets, and has made due allowance in his bid for all contingencies.

Include in bid all costs of labor, material, equipment, allowance, fees, permits, guarantees, applicable taxes (**sales tax does not apply**), insurance and contingencies, with overhead and profit necessary to complete those portions of the work covered by the specifications on which proposal is made, including all trades, without further cost to the Owner. Obtain all permits and arrange for all inspections. Pay all fees, permits and costs incurred.

No compensation will be allowed by reason of any difficulties, which the Bidder could have discovered prior to bidding.

7. Materials

Materials shall conform to the drawings, specifications, manufacturer's specifications for all products incorporated into the work, and all applicable standards and guidelines.

Some specific equipment and materials have been specified for use on this project to establish minimum performance requirements or desired features. To receive consideration of alternate equipment or materials, the Bidder must submit all appropriate product data and receive pre-bid approval from the Owner prior to bid. All materials are subject to the approval by the Owner both before and after incorporation in the project.

All condemned material or work shall be removed from the premises and properly disposed of.

8. Law Compliance

All project construction work shall comply with all State and Municipal Laws and Regulation, and with all Local Ordinances and Rules pertaining to this work. Such Laws, Regulations, Ordinances and Rules shall be considered a part of these specifications.

9. Expediting

Place orders for materials and equipment immediately upon receipt of Contract or Notice to Proceed and follow up vigorously to insure adequate and timely supply to the work. Perform all tracings and expediting actions and arrange to get workmen in the job at the proper time to avoid delays.

10. Guarantee

The Contractor and/or manufacturer shall provide a minimum of one (1) year warranty for all materials and workmanship associated with the project or work performed under the Contract.

11. Insurance

- a. General: The Contractor shall not commence work under the Contract until he has obtained all insurance required, and it has been approved by the Owner, nor shall Contractor allow any Subcontractor to commence work on any portion of the work until all insurance required of the Subcontractor and Sub-subcontractor has been similarly approved by the Owner.

All such insurance shall be purchased only from companies licensed and duly authorized by the Department of Insurance of the State of Illinois to do business in Illinois and to write the types of insurance policies as herein specified. Insurance companies must have a minimum policy holder's rating of A+ and a financial rating of AAAAA as stated in the latest edition of Best's Insurance Guide.

The insurance coverages must be maintained by the Contractor and the Subcontractor until all work is completed by the Contractor and accepted by the Owner. If the policy is written on claims made basis, then the Contractor shall purchase such additional insurance as may be necessary to provide specified coverage to the District for a period of not less than five (5) years from the completion of the work.

- b. Automobile Liability: Contractor shall obtain at his expense and keep in force at all times during the performance of the work, Comprehensive Automobile Liability Insurance providing for bodily injury, personal injury and property damage, limits of an amount not less than \$1,000,000 per occurrence and \$2,000,000 per annual aggregate.
- c. General Liability Insurance: Contractor shall obtain at his expense and keep in force at all times during the performance of the work, Comprehensive General Liability Insurance providing for bodily injury, personal injury and property damage, limits of not less than \$1,000,000 per occurrence and \$2,000,000 annual aggregate.
- d. Worker's Compensation and Employer's Liability Insurance: Contractor shall obtain at his expense and keep in force at all times during the performance of work, worker's compensation and related insurance coverage at amounts required by statute and employer's liability with limits of not less than \$1,000,000 per occurrence

- e. Certificates of Insurance: Within ten (10) calendar days after receipt of the "Written Notice to Proceed", the Contractor shall file with the Owner, a Certificate of Insurance showing complete coverage of all insurance required by this Section signed by the insurance companies or their authorized agents, certifying to the name and address of the party insured, the description of the work covered by such insurance, the insurance policy numbers, the limits of liability of the policies and the dates of their expirations, with a further certification from said insurance companies that their policies will not be modified, amended, changed, cancelled or terminated without thirty (30) business days prior written notice to the Owner. If any form of umbrella or excess coverage policy is utilized by the Contractor, the Owner reserves the right to require a copy of the entire policy.

12. Indemnification

The Contractor agrees to protect, indemnify, hold and save harmless and defend the Hoffman Estates Park District, its public officials, employees, volunteers, and agents against any and all claims, costs, causes, actions and expenses, including but not limited to attorney's fees incurred by reason of lawsuit or claim for compensation arising in favor of any person, including the employees or officers or independent contractors or subcontractors of the Contractor or Park District, on account of personal injuries or death, or damages to property occurring, growing out of, incident to, or resulting directly or indirectly from the performance by the "Contractor or Subcontractor", hereunder, whether such loss, damage, injury or liability is contributed to by the negligence of the Park District or by the premises themselves or any equipment thereon whether latent or patent, or from any other cause whatsoever, except that the Contractor shall have no liability or damages or the costs incident thereto caused by the sole negligence of the Park District.

13. Labor Law

The Contractor and each and every Subcontractor performing work at the site of the project to which this Contract relates shall comply with applicable and provisions of all pertinent Federal, State, and Local Labor Laws.

14. Time Schedule/Major Repairs

Work under the Contract shall commence within five (5) calendar days after given "Written Notice to Proceed" by Owners (or date specified) and shall continue with due diligence until due completion.

The Contractor shall agree to a time schedule setting up order of procedure and time allowed for each branch of work. Contractor shall make every effort to adhere to these schedules, but reasonable modifications will be permitted from time to time to compensate for delays due to strikes or conditions beyond Contractor's control, exclusive of weather.

15. Assignment

The Contractor or any Subcontractor shall not assign the Contract nor any monies due to become due to him hereunder, to any Person, Firm, or Corporation without previous written consent of the Owner.

16. Extras

No extra work shall be allowed or paid for unless a Change Order is made and accepted by the Owner in writing.

17. Liens

No payment shall become due until the Contractor, if required, shall deliver to Owner a complete release of all liens arising out of this Contract, or receipts in full in lieu thereof and, if required in either case, an affidavit that so far as he has knowledge or information, the releases and receipts include all the labor and material for which a lien could be filed. If any lien remains unsatisfied after all payments are made, the Contractor shall refund to the Owner all monies that the latter may be compelled to pay in discharging such a lien, including all costs and a reasonable attorney's fee.

18. Default

In case of default by the Contractor, the Owner may procure the articles or services from other sources and hold the Contractor responsible for any excess cost occasioned thereby.

19. Cancellation of Contract

If the Contractor or any of his Sub-contractors shall, in the judgment of the Hoffman Estates Park District, be unable to carry on the work satisfactorily, or if the Contractor or any of his Sub-contractors shall violate any of the provisions of this contract, or in case of bankruptcy of the Contractor, or failure of the Contractor to pay for supplies or workmen, or a work-stoppage, or a failure by the Contractor to provide sufficient workmen or sufficient material for the job, the Owner may serve written notice upon the Contractor and his Surety of his intention to terminate the Contract, and, if within seven (7) days after the service of such notice, the Contractor or the Sub-contractor or the Surety have not proceeded to carry on the work in accordance with this Contract and to the satisfaction of the Owner, this Contract shall cease and terminate and the Owner shall have the right to take over the work and prosecute the same to completion by Contract for the account and at the expense of the Contractor and the Surety; and the Contractor and Surety shall be liable to the Owner for any excess costs occasioned by the Owner thereby, and in such event the Owner may take possession of and utilize in completing the work such materials, appliances, and

plants as may be on the site of the work and necessary therefore; provided, however, that in the event the Owner determines that the failure of the Contractor, Sub-contractor or Surety to carry on the work in accordance with this Contract has resulted in an emergency which will require that the Owner take over the work immediately, to avoid loss or waste of a substantial part of the work already performed, the Owner may immediately take over the work and prosecute the same at the expense of the Contractor and Surety to the extent necessary to avoid damage, and may prosecute

the same at the expense of the Contractor and Surety to the extent necessary to avoid damage, and may prosecute the same to completion at the expense of the Contractor and the Surety unless within seven (7) days after the services of the above described notice, the Contractor, Sub-contractor or Surety has proceeded to carry on the work in accordance with this Contract and to the satisfaction of the Hoffman Estates Park District.

20. Lien Waivers (if applicable)

Neither by partial nor final payment will the Owner be deemed to have waived any remedy for defective work or negligence on the part of the Contractor or any other portion of the Contract which, by its nature, survives after time of payment.

Supporting partial Waivers of Lien for each Subcontractor, supplier and prime contractor must accompany each request for progress payment.

Waivers must spell out exact description of work performed for which Waiver is issued and state whether dollar amount is full amount received or amount of work less retainage, held by prime contractor.

For final payment it is necessary to submit final waivers in the full amount of the Contracts for all Subcontractors, suppliers and prime contractors.

Waivers must be accompanied by a sworn statement listing Subcontractors and suppliers, the amount of their Contracts and the amount requested.

21. Illinois Prevailing Wage Provision

The Contractor and /or supplier doing work on the project and **on the owner's premises** shall comply with the Illinois Prevailing Wage Ordinance adopted by the Hoffman Estates Park District. The provision states that all labor required to complete the project will be paid at no less than the prevailing rate determined by the Illinois Department of Labor.

The Contractor and each subcontractor is required to provide at the time of pay request or at least once monthly, a copy of a certified payroll of labor used in conjunction with the project(s). The certification shall include each worker's name, address, telephone number (when available), Social Security Number, classification(s), and the occupation of all laborers, workers and mechanics employed by the Contractor and each subcontractor in conjunction with the project(s). The records shall also show the actual hourly wages paid in each pay period to each employee and the number of hours worked each day and in each workweek by each employee. While participating on a park project, each contractor's payroll records shall include the starting and ending times of work each day for each employee.

Should there be no request for payment presented to Hoffman Estates Park District, the Contractor shall submit the certified payroll records monthly either by mail or electronically to the Hoffman Estates Park District.

The certified payroll shall be accompanied by a statement by the Contractor or subcontractors which avers: such records are true and accurate; the hours by rate paid to each worker is not less than the general prevailing wages as required by the Prevailing Wage Act; and the Contractor or subcontractor is aware that the filing of a certified payroll that he/she knows to be false is a Class B misdemeanor. The Hoffman Estates Park District shall accept any reasonable submission by the Contractor that meets the requirement of the Prevailing Wage Act.

SPECIFICATIONS

- Model must be Range Servant Tee Box Bay Dispenser Model: Tee Box 2 Integrated
- Quantity 10 Units
- Yearly license fee included
- Installation and set up
- Customize design to match our facility
- Sell balls by time at the bay or by quantity
- Stores up to 1800 golf balls in each dispenser
- Sensor for balls to dispense directly onto the mat with club wave
- Dimensions and spec must meet the sheet below:

This drawing remains our property and should not be copied without our written allowance. Nor it is permitted to show or give this to a third person. Contravention will be prosecuted with the support of the existing law.

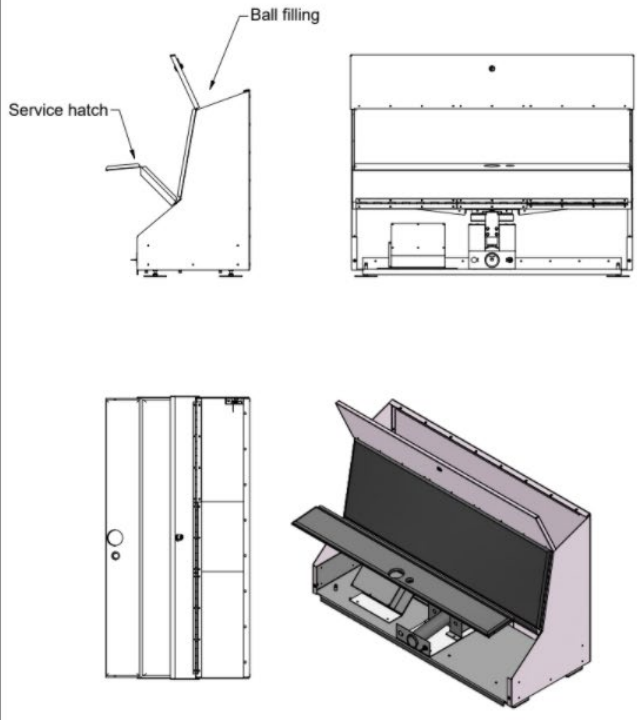

Rev	Amendment	Date	Inf.	App.

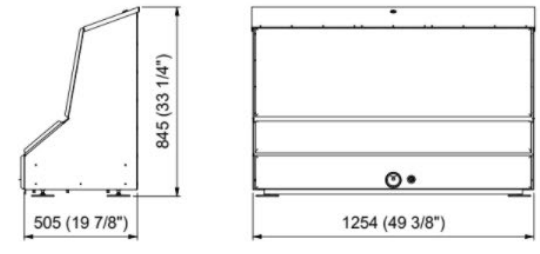

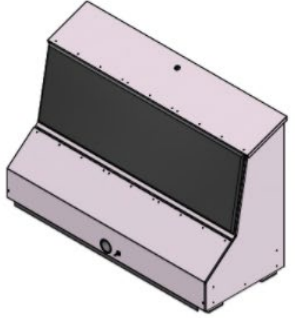

Det.	Quant.	Name	Material	Dimension	Remark
Designed FH		Drafted FH	Checked	Approved	Tolerance ISO 2768-m, unless otherwise indicated.
		RANGE SERVANT SKALLEBACKAVÄGEN 11 SE-302 41 HALMSTAD, SWEDEN		TeeBox ON/OFF version TB2X	
					Drawing No. 1000154
					Replaced With Rev

Must have Network Capabilities to Toptracer Range:

TBOX with CONNECTED CARE

Example of 8 Bay Solution
Individual TBOXES are networked to Network Switch
Network switch is connected to Top Tracer Server

