

Bidder Name: \_\_\_\_\_  
Address: \_\_\_\_\_  
Telephone #: \_\_\_\_\_  
Facsimile: \_\_\_\_\_

**SUPPLY AND INSTALLATION OF FENCING  
FOR MAPLE PARK PLAYGROUND,  
EVERGREEN PARK PLAYGROUND  
HIGH POINT PARK**

**BID DATE: February 24, 2015**

**BID TIME: 10:00 a.m.**

PREPARED BY:

HOFFMAN ESTATES PARK DISTRICT  
1685 W. Higgins Road  
Hoffman Estates, IL 60169-2998  
Telephone: (847) 885-7500  
Facsimile: (847) 885-7523

## HOFFMAN ESTATES PARK DISTRICT

### TABLE OF CONTENTS

- ❖ Invitation to Bidders
- ❖ Instructions to Bidders
- ❖ Supplementary Conditions
- ❖ Specifications
- ❖ Proposal
  - ◆ Bid Proposal Form
  - ◆ Bid Certification Form
  - ◆ List of Subcontractors
  - ◆ Contract Compliance Attachment
  - ◆ Reference List
  - ◆ Illinois Department of Labor Prevailing Wage Rates
  - ◆ Certifications

January 6, 2015

Dear Bidder:

Enclosed you will find the plans, specifications and bidding materials for **SUPPLY AND INSTALLATION OF FENCING FOR MAPLE PARK PLAYGROUND, EVERGREEN PARK PLAYGROUND AND HIGH POINT PARK**. Pertinent information is included in the attached package. Please submit the Proposal Forms, Certification, References, and Bid Bonds. Please copy your proposal and retain one copy for your records.

I look forward to reviewing your bid proposal and working with you on this project. If you have further questions or need to meet at the site, please contact me 847-561-2172. I can be reached Monday through Friday from 8:30 a.m. until 4:00 p.m.

Sincerely,

Gary Buczkowski  
Division Director  
Planning and Development

## INVITATION TO BIDS

Sealed bids for **SUPPLY AND INSTALLATION OF FENCING FOR MAPLE PARK PLAYGROUND, EVERGREEN PARK PLAYGROUND AND HIGH POINT PARK** will be received by the Hoffman Estates Park District at our office; 1685 West Higgins Road, Hoffman Estates, Illinois 60169 until **exactly 10:00 A.M., FEBRUARY 24, 2015**, and then publicly opened and read. Bids submitted after the closing time will be returned unopened. No oral or telephone proposals or modifications will be considered.

The Hoffman Estates Park District Board of Commissioners will make the final award.

Proposals shall be submitted on the attached Form of Proposal and returned in the envelope, if provided. No bidder may withdraw his proposal after the hour set for the opening thereof, or before award of the contract, unless said award is delayed for a period exceeding sixty (60) calendar days.

The Hoffman Estates Park District requires all bidders to comply with all provisions of the Park District Prevailing Wage Ordinance O-14-003. This ordinance specifies that no less than the general prevailing rate of wages as found by the Park District or Department of Labor or determined by a court on review shall be paid each draft type of worker or mechanic needed to execute the contract or perform the work.

The Hoffman Estates Park District may reject any or all of the bids on any basis and without disclosure of a reason. The failure to make such a disclosure shall not result in accrual of any right, claim, or cause of action by any unsuccessful Bidder against the Hoffman Estates Park District.

Bid results and the award of the bid will be published on the Hoffman Estates Park District website [www.heparks.org](http://www.heparks.org).

Sincerely,

Gary Buczkowski  
Division Director, Planning and Development

HOFFMAN ESTATES PARK DISTRICT

INSTRUCTIONS TO BIDDERS

1. Identification of Project

The official name and location of the project shall henceforth be known as:

**SUPPLY AND INSTALLATION OF FENCING FOR MAPLE PARK  
PLAYGROUND, EVERGREEN PARK PLAYGROUND AND HIGH  
POINT PARK**

The official name and address of the project owner shall henceforth be known as:

HOFFMAN ESTATES PARK DISTRICT  
1685 West Higgins Road  
Hoffman Estates, IL 60169-2998

Bid Opening: February 24, 2015 – 10:00 a.m.

Committee Approval: March 3, 2015

Board Approval: March 24, 2015

Contract Awarded: March 25, 2015

Commencement of Work: Commencement of paperwork shall begin in a timely manner upon notification of award.

2. Contract Documents

The Notice to Bidders, the Instructions to Bidders, the Supplementary Conditions, Drawings, Specifications, the supplied Form of Proposal, the accepted Bid Sheet and certification comprise the Contract Documents. Copies of these documents can be obtained in person from the office of the Hoffman Estates Park District, 1685 W. Higgins Road, Hoffman Estates IL 60169-2998.

### 3. Explanation to Bidders

Any explanation desired by a bidder regarding the meaning or interpretation of the invitation for bids, drawings, specifications, etc., must be requested in writing and with sufficient time allowed for a reply to reach bidders before the submission of their bids.

Any interpretation made will be in the form of an amendment of the invitation for bids, drawings, specifications, etc., and will be furnished to all prospective bidders. Its receipt by the bidder must be acknowledged in the space provided on the Bid Form or by letter or telegram received before the time set for opening of bids. Oral explanations or instructions given before the award of the contract will not be binding.

### 4. Conditions Affecting the Work

Bidders should visit the site and take such other steps as may be reasonably necessary to ascertain the nature and location of the Work, the general and local conditions, which can affect the Work or the cost thereof. Failure to do so will not relieve bidders from responsibility for estimating properly the difficulty or cost of successfully performing the Work.

### 5. Bid Guarantee, Bonds and Required Paperwork

- A. A **Bid Guarantee, five (5%) percent**, is required by the invitation for bids. Failure to furnish a Bid Guarantee in the proper form and amount by the time set for opening of bids may be cause for rejection of the bid in the absolute discretion of the Owner.
- B. A Bid Guarantee shall be the form of a bid bond, postal money order, certified check, or cashier's check made payable to the Owner. Bid guarantees, other than those stated, will be returned to the bidder upon opening of bids. Such bids will not be considered for award (a) to unsuccessful bidders as soon as practical after the award of the job, and (b) to the successful bidder upon execution of such further contractual documents and bonds as may be required by the bid as accepted.
- C. The successful bidder, upon being given a "Written Notice to Proceed", will have five (5) calendar days to provide the required Labor and Material Payment Bond, Performance Bond, and Insurance Policies or certificates for same, and commence with the Work. Failure to comply with the conditions set forth in the Contract Documents shall result in the termination of the contract for default. In such event, the Contractor may be liable for any costs of performing the work which

exceed the amount of his bid, and the Bid Guarantee shall be available toward offsetting such difference, if not previously returned to the Contractor.

## 6. Preparation and Submission of Bids

Before submitting proposal, each bidder shall carefully examine all documents pertaining to the Work and visit the site to verify conditions under which Work will be performed.

Submission of bid will be considered presumptive evidence that the Bidder has visited the site and is conversant with local facilities and difficulties, the requirements of the documents and of pertinent State or Local Codes, State of Labor and Material Markets, and has made due allowance in his bid for all contingencies. Include in bid all costs of labor, material, equipment, contractor's license, permits, guarantees, applicable taxes (sales tax does not apply), insurance and contingencies, with overhead and profit necessary to produce a completed project, or to complete those portions of the Work necessary to produce a completed project, or to complete those portions of the Work covered by the specifications on which proposal is made, including all trades, without further cost to the Owner. The Owner shall be responsible for the building permit fee.

No compensation will be allowed by reason of any difficulties which the Bidder could have discovered reasonably, prior to bidding.

All proposals must be made upon the Proposal Form furnished by the Owner attached hereto and should give the amounts bid for work, in numbers, and must be signed and acknowledged by the contractor. The Proposal should be enclosed in the envelope marked "Bid Proposal for Hoffman Estates Park District **SUPPLY AND INSTALLATION OF FENCING FOR MAPLE PARK PLAYGROUND, EVERGREEN PARK PLAYGROUND AND HIGH POINT PARK**" showing the return address of the sender and addressed to: Hoffman Estates Park District, 1685 W. Higgins Road, Hoffman Estates, Illinois 60169. Bids should be sealed, marked and addressed as directed above. Failure to do so may result in a premature opening of or a failure to open such bid.

The proposal submitted must not contain erasures, inter-lineations, or other corrections unless each correction is suitably authenticated by affixing in the margin immediately opposite the correction the surname or surnames of the person or persons signing the bid.

Modifications of bids already submitted will be considered if received at the office designated in the invitation for bids by the time set for opening of bids. Telegraphic modifications will be considered, but should not reveal the amount of the original or reversed bid.

7. Prices

The prices are to include the furnishing of all materials, equipment, tools, insurance, bonds, warranties, and all other facilities, and the performance of all labor and services necessary for the proper completion of the Work except as may be otherwise expressly provided in the Contract Documents.

8. Time Schedule

The timely execution of any project is extremely important. The successful bidder shall take every means to meet the completion date stated above except for extensions granted by the Owner in writing for circumstances beyond the control of the Bidder.

9. Late Bids and Modifications or Withdrawals

Bids and modifications or withdrawals thereof received at the office designated in the invitation for bids after the exact time set for opening of bids will not be considered.

10. Withdrawal of Bids

Bids may be withdrawn by written or telegraphic request received from bidders prior to the time set for opening of bids.

11. Public Opening of Bids

Bids will be publicly opened at the time set for opening in the invitation for bids. Their content will be made public for the information of bidders and others interested, who may be present either in person or by representative.

12. Award of Contract

- A. Award of Contract will be made to the lowest responsible bidder, as determined by the Board of Commissioners of the Hoffman Estates Park District, whose bid conforms to the invitation for bid.
- B. The Board of Park Commissioners may reject any or all of the bids on any basis and without disclosure of a reason. The failure to make such a disclosure shall not result in accrual of any right, claim, or cause of action by any unsuccessful bidder against the Hoffman Estates Park District.



13. Contract and Insurance

The written contract between the accepted bidder and the Owner shall be considered finalized and entered into between the parties upon the Park District Board's approval and award of the contract to the accepted bidder and the Park District's execution of the accepted bidder's Form of Proposal, and said written contract shall be comprised by the Contract Documents. The accepted bidder shall provide the Owner with a Labor and Material Payment Bond, Performance Bond, and copies of applicable Insurance Policies and endorsements and certificates for same within five (5) calendar days of the "Written Notice to Proceed" and prior to the commencement of work.

14. Postponement of Date for Opening Proposals

The Owner reserves the right to postpone the date of presentation and opening of proposals and will give telegraphic notice of any such postponement to each interested party.

## SUPPLEMENTARY CONDITIONS

### SECTION I – GENERAL

#### 1. Application

These Supplementary Conditions shall be used in conjunction with and are a part of any and all Sections of the Specifications and all Contracts and Subcontracts that may be made for the completion of the work in all its parts as identified and described in the Contract Documents.

#### 2. Definitions

Owner: The Hoffman Estates Park District, Board of Commissioners, Staff and its appointed Owner's representative.

Contractor: A firm, corporation or individual with whom the Owner makes a direct Contract for the construction of all or any portion of the work.

Architect/Engineer: The authorized representative of the Owner.

Subcontractor: A firm, corporation or individual other than employees of a Contractor with whom a Contractor or Subcontractor makes a contract to furnish labor, and/or materials, and/or services in connection with the project.

Owner Representative: An employee of the Hoffman Estates Park District responsible for the coordination of the work involved on the project.

The words "approve", "equal to", "as directed", etc., are interpreted and will be taken to mean "to the satisfaction of the Owner." Samples shall be submitted and approvals shall be requested in ample time to avoid any delays should resubmission of an item be necessary.

#### 3. Contract Documents

The Contract Documents shall consist of the Notice to Bidders, the Instructions to Bidders, the Supplementary Conditions, the Drawings, the Specifications, the supplied Form of Proposal, and the accepted Bid Sheet and certification.

#### 4. Bonds

- A. With proposal, and attached hereto, each Bidder shall furnish Bid Security payable to the Owner in the amount of 5% of bid.
- B. Include allowance in Lump Sum Proposal for Performance Bond and Labor and Materials Payment Bond in the amount of 100% of Contract Price.

1. The Contractor, before commencing the Work, shall furnish a Performance Bond and a Labor and Material Bond. The Performance Bond shall be in an amount equal to 100% of the full amount of the Contract Sum as security for the faithful performance of the obligation of the Contract Documents, and the Labor and Material Payment Bond shall be in an amount equal to 100% of the full amount of the Contract Sum as security for the payment of all persons performing labor and furnishing materials in connection with the Contract Documents. Such bonds shall be on standard AIA Documents, issued by the American Institute of Architect/Engineers, shall be issued by a surety satisfactory to the Owner, and shall name the Owner as a primary co-obligee. The cost of the bonds is to be included in the Bid Proposal. The Performance Bond and Labor and Material Payment Bond will become a part of the Contract. Each Bidder shall list the name of the surety company that will be furnishing the Bonds on its Bid Proposal. The failure of a Bidder to list the name of its surety company on its Bid Proposal shall be a non-responsive bid. The failure of the successful Bidder to supply the required Bonds within five (5) days after the Notice of Award or within such extended period as the Owner may grant if the forms do not meet its approval shall constitute a default, and the Owner may either award the Contract to the next responsible, responsive Bidder or re-advertise for bids. A charge against the defaulting Bidder may be made for the difference between the amount of the bid and the amount for which a contract for the work is subsequently executed, irrespective of whether the amount thus due exceeds the amount of the bid guarantee.
2. The Contractor shall deliver the required bonds to the Owner not later than five (5) days following the date the Agreement is entered into, or if the Work is to be commenced prior thereto in response to a letter of intent, the Contractor shall, prior to the commencement of the Work, submit evidence satisfactory to the owner that such bonds will be furnished.
3. The contractor shall require the attorney-in-fact who executed the required bonds on behalf of the surety to affix thereto a certified and current copy of the power of attorney.
4. Whenever the Contractor shall be and is declared by Owner to be in default under the Contract, the Surety and the Contractor are each responsible to make full payment to the Owner or any and all extra Work incurred by the Architect/Engineer as a result of the Contractor's default, and to pay to Owner all attorney's fees and court costs incurred by Owner as a result of the Contractor's default, and in protecting Owner's rights under the Agreement to remedy Contractor's default.

5. The Contractor shall (i) furnish all Surety Company's bonds through Surety Company's local agents approved by and/or as directed by Owner; (ii) fully covered and guarantee with said bond the faithful performance and completion of the entire Contract, including without limitation, the faithful performance of prevailing wage requirements; and (iii) guarantee with said bond payment in all cases by the Contractor or by the Surety Company for all labor performed, material and supplies furnished with the entire Work in the Contract. Said Bond shall remain in full force and effect during the entire period of all general guarantees given by the Contractor with the Contract as called for in the Specifications and Contract, except in cases where other bonds are specifically called for in the specifications and Contract in connection with special guarantees.

#### 5. Payment

The Contractor may present estimate of work for which he desires payment no later than the first Monday of each month, based on cost of labor and material incorporated into the work. Estimate shall be a Sworn Statement and shall show relative amount of each item completed. Submit Partial Waivers of Lien, including for first payout, from Contractors, Subcontractors and Material Suppliers with Sworn Statement for monthly payout. Payments will be made within approximately thirty (30) days after review by the Owner. Notwithstanding, anything to the contrary contained in the Contract Documents, payouts are to be made by checks payable to the Contractor. The Contractor will be required to submit a sworn payroll statement according to the Illinois Department of Labor documenting his compliance with the Illinois Prevailing Wage Act.

Final Payment will be made within approximately thirty (30) days of final inspection and approval and receipt of all waivers, sworn statements, guarantee statements, and other documents set forth in the Contract Documents.

#### 6. Preparation of Bids

Before submitting proposal, each bidder shall examine carefully all documents pertaining to the work and visit the sites to verify conditions under which work will be performed. Submittal of the Bid Proposal by the Contractor is a representation by the Contractor, that the Contract Documents are full and complete, are sufficient to enable the Contractor to determine the cost of the Work and that the Contract Documents are sufficient to enable it to construct the Work outlined therein, in accordance with applicable laws and regulations, and otherwise to fulfill all its obligations hereunder, including, but not limited to, Contractor's obligations to construct the Work for an amount not in excess of the

contract Sum on or before the date(s) of Completion established in the Agreement. The Contractor further acknowledges and declares that it has visited and examined the Project site, examined all physical and other conditions affecting the Work and is fully familiar with all of the conditions thereon and thereunder affecting the same. In connection therewith, Contractor specifically represents and warrants to Owner that prior to the submission of its bid it has: (a) thoroughly examined the location of the work to be performed, is familiar with local conditions, and has read and thoroughly understands the Contract Documents as they relate to the physical conditions prevalent or likely to be encountered in the performance of the work at such location; (2) examined the nature, location and character of the general area in which the Project is located, including without limitation, its climatic conditions, available labor supply and labor costs, and available equipment supply and equipment costs; and (3) examined the quality and quantity of all materials, supplies, tools, equipment, labor, and professional services necessary to complete the Work in the manner and within the cost and time frame required by the Contract Documents.

Submission of bid will be considered presumptive evidence that the Bidder has visited the site and is conversant with local facilities and difficulties, the requirements of the documents and of pertinent State, County or Local Codes, State of Labor and Material Markets, and has made due allowance in his bid for all contingencies.

Include in bid all costs of labor, material, equipment, allowance, fees, permits, guarantees, applicable taxes (**sales tax does not apply**), insurance and contingencies, with overhead and profit necessary to complete those portions of the work covered by the specifications on which proposal is made, including all trades, without further cost to the Owner. Obtain all permits and arrange for all inspections. Pay all fees, permits and costs incurred.

No compensation will be allowed by reason of any difficulties, which the Bidder could have discovered prior to bidding.

#### 7. Fees and Inspection

The Contractor is responsible for all license fees and arrangements for all inspections required by State, County, Local and other authorities having lawful jurisdiction. The Owner is responsible for all building permit fees associate with the Work.

## 8. Subcontracts

Contractors operating under direct Contracts with the Owner may let Subcontracts for the performance of such portions of the work as are usually executed by special trades. All such Subcontracts shall be based on conformance with all pertinent conditions set forth in the Contract Documents, including the Supplementary Conditions as well as the detailed requirements of the portions of the drawings and specifications which depict or describe the work (labor and materials) covered by the Subcontract.

No Work may be sublet without approval of the Owner, who reserves the right to disapprove any proposed Subcontractor whose record does not establish his experience, competence, and financial ability to perform the work.

## 9. Materials

Materials shall conform to the drawings, specifications, manufacturer's specifications for all products incorporated into the work, and all applicable standards and guidelines.

Some specific equipment and materials have been specified for use on this project to establish minimum performance requirements or desired features. To receive consideration of alternate equipment or materials, the Bidder must submit all appropriate product data and receive pre-bid approval from the Owner. All materials are subject to the approval by the Owner both before and after incorporation in the project.

All condemned material or work shall be removed from the premises and properly disposed of.

## 10. Law Compliance

All project construction work shall comply with all State and Municipal Laws and Regulation, and with all Local Ordinances and Rules pertaining to this work. Such Laws, Regulations, Ordinances and Rules shall be considered a part of these specifications.

- A. The Contractor warrants that it is familiar with and shall comply with Federal, State and local laws, statutes, ordinances, rules and regulations and the orders and decrees of any courts or administrative bodies or tribunals in any manner affecting the performance of the Contract including without limitation Workers= Compensation Laws, minimum salary and wage statutes and regulations, laws with respect to permits and licenses and fees in connection therewith, laws

regarding maximum working hours. No plea of misunderstanding or ignorance thereof will be considered.

- B. Whenever required, the Contractor or Subcontractor shall furnish the Architect/Engineer and Owner with satisfactory proof of compliance with said Federal, State and local laws, statutes, ordinances, rules, regulations, orders, and decrees.
- C. Contractor shall carefully examine the Occupational Safety and health Act as issued by the Federal Register (OSHA), and the specific regulations governing procedures, techniques, safety precautions, equipment design, and the configuration of the same as required under this Act and shall comply with all terms of the Act and to perform and complete in a workmanlike manner all work required in full compliance with said Act.
- D. Contractor shall comply with all terms of the Illinois Preference Act and all terms of the Equal Employment Opportunity Clause of the Illinois Fair Employment Practices Commission.
- E. At all times Contractor shall remain in compliance with the Illinois Public Works Employment Discrimination Act (775 ILCS 10/1, et seq.) and the Illinois Human Rights Act (775 ILCS 5/2-101, et seq.), and in addition shall at all times comply with Section 2-105 of the Illinois Human Rights Act requiring a written sexual harassment policy as defined therein.
- F. Contractor and all subcontractors shall be solely responsible for complying with the Substance Abuse Prevention on Public Works Projects Act, Public Act 095-06345.
- G. Contractor agrees to maintain all records and documents for projects of the District in compliance with the Freedom of Information Act, 5 ILCS 140/1 et seq. In addition, Contractor shall produce records which are responsive to a request received by the District under the Freedom of Information Act so that the District may provide records to those requesting them within the time frames required. If additional time is necessary to compile records in response to a request, then Contractor shall so notify the District and if possible, the District shall request an extension so as to comply with the Act. In the event that the District is found to have not complied with the Freedom of Information Act due to Contractor's failure to produce documents or otherwise appropriately respond to a request under the Act, then Contractor shall indemnify and hold the District harmless, and pay all amounts determined to be due including but not limited to fines, costs, attorney's fees and penalties.
- H. Contractor understands, represents and warrants to the Owner that the Contractor and its Subcontractors (for which the Contractor takes responsibility to insure that they comply with the above-mentioned Acts) are in compliance with all requirements provided by the Acts set forth in Article 15 and that they will remain in compliance for the entirety of the Work. A violation of any of the Acts set forth in this

Article is cause for the immediate cancellation of the Contract. However, any forbearance or delay by the Owner in canceling this Contract shall not be considered as, and does not constitute, Owner's consent to such violation and a waiver of any rights the Owner may have, including without limitation, cancellation of this Contract.

- I. Contractor and each of its Subcontractors shall pay prevailing wages as established by the Illinois Department of Labor for each craft or type of work needed to execute the contract in accordance with 820 ILCS 130/01 et seq. The Contractor shall prominently post the current schedule of prevailing wages at the Contract site and shall notify immediately in writing all of its Subcontractors, of all changes in the schedule of prevailing wages. Any increases in costs to the Contractor due to changes in the prevailing rate of wage during the terms of any contract shall be at the expense of the Contractor and not at the expense of the Owner. The change order shall be computed using the prevailing wage rates applicable at the time the change order work is scheduled to be performed. The Contractor shall be solely responsible to maintain accurate records as required by the prevailing wage statute and shall be solely liable for paying the difference between prevailing wages and any wages actually received by laborers, workmen and/or mechanics engaged in the Work

#### 11. Supervision

The Contractor shall maintain a highly qualified technician on the job site at all times. The Contractor shall enforce strict discipline and good order among his employees and the Subcontractors at all times work is in progress. The Contractor shall not employ any unfit person or anyone not skilled in the work assigned to him.

#### 12. Equipment and Tools

Furnish and maintain all equipment tools and apparatus, scaffolding, and all temporary work and materials necessary to perform the work.

#### 13. Expediting

Place orders for materials and equipment immediately upon receipt of Contract or Notice to Proceed and follow up vigorously to insure adequate and timely supply to the work. Perform all tracings and expediting actions and arrange to get workmen in the job at the proper time to avoid delays.

#### 14. Sanitary

The Contractor shall provide suitable, temporary toilet facilities at a specified location, for workmen on the project, complying in every respect



with Local and County requirements. Unit shall be chemically treated, serviced at regular intervals, and maintained in a sanitary condition at all times.

#### 15. Existing Utilities

The Contractor shall be responsible for locating and protecting all existing utilities, public and private, for the duration of the job. Prior to the commencement of any work, the Contractor shall notify all public and private utilities for the purpose of verifying, marking, and recording the locations of all under ground or overhead utilities, temporary or permanent. Any repair/replacement costs or associated damage will be the responsibility of the Contractor.

#### 16. Testing and Observations

The Contractor shall give the Owner, Village Inspector, and Manufacturer's Representative proper notice of readiness of Work for all required observations, tests, or reviews.

If Laws or Regulations of any public body having jurisdiction requires any Work (or part thereof) to specifically observed or tested, Contractor shall assume full responsibility therefor, pay all costs in connection therewith and furnish Engineer with the required certificates of inspection, testing, or approval. Contractor shall be responsible for and pay all costs in connection with any inspection or testing required in connection with Owner's or Manufacturer's agreed to Supplier of materials or equipment proposed to be incorporated into the Work, or of materials or equipment submitted for approval prior to the Contractor's purchase thereof for incorporation in the Work.

The cost of all observations, tests, and approvals in addition to the above which are required by the Contract Documents shall be paid by the Owner (unless otherwise specified).

All observations, tests, or reviews other than those required by Laws or Regulations of any public body having jurisdiction shall be performed by organizations agreed to by Owner and Contractor (or Manufacturer if so specified).

**Should testing reveal deficiencies due to Contractor error, subsequent testing costs shall be paid by Contractor.**

If any work (including the work of others) that is to be observed or tested is covered without the written concurrence of the Owner, it must, if requested by Engineer, be uncovered of observation. Such uncovering shall be at

the expense of the Contractor unless Contractor has given Owner or Village Inspector timely notice of Contractor's intention to cover such work and Engineer has not acted with reasonable promptness in response to such notice. Neither observations by Owner nor observations, tests, nor reviews by others shall relieve the Contractor from his obligations to perform the work in accordance with the Contract Documents.

17. Acceptance Preceding Work (if applicable)

Before starting any operation, the Contractor and Subcontractors shall examine work performed by others to which his work adjoins or is applied and report any condition that will prevent satisfactory accomplishment of his Contract. Failure to notify the Owner in writing of deficiencies or faults in preceding work will constitute acceptance thereof and waiver of any claims and its unsuitability.

18. Cutting and Patching

When necessary to cut or alter completed work to accommodate another trade, the Contractor or Subcontractor for work in places, shall do all cutting for and repair of portions of the work so disturbed. Where cutting is necessitated by fault or negligence of another Contractor, all costs of cutting and repairing shall be borne by the party at fault.

19. Damage to Current

Each Contractor shall adequately protect all preceding work from damage caused by him or his works. All breakage or damage will be repaired by trade concerned at the cost of the party causing damage. Each Contractor, however, shall be responsible for adequate protection of his own work against normal construction risks.

20. Housekeeping

Keep site of operations free from accumulations of rubbish and waste materials at all times. See that Subcontractors remove and dispose of their rubbish. Arrangements for removal and disposition of rubbish will be made by Contractors concerned at no cost to the Owner.

Should any Contractor or Subcontractor allow rubbish or waste material to accumulate on any portion of the site or in any portion of the building to such extent that the accumulation constitutes a hazard or obstructs the prosecution of the work in any way. The Owner may, if Contractor or Subcontractor at fault fails to remove such rubbish or waste materials within three (3) days after written notice to clear up the accumulation, engage prior labor or services of another Contractor to make necessary

removal and disposition and to charge cost against monies due to Contractor or Subcontractor at fault.

## 21. Protection

- A. Property: Each Contractor and Subcontractor shall take such precaution as are necessary adequately to protect from damage or deterioration and to safeguard from theft or pilferage, all materials, tools and equipment pertaining to his work which are on the site, whether stored or incorporated in the structure.
- B. Safety: Provide all barricades or other temporary protection as may be required by local authorities having lawful jurisdiction, or be considered of general safety, around all openings in floors and walls of the structure, and around all open pits or trenches in its vicinity.
- C. Weather: Each Contractor and Subcontractor shall at all times provide protection against rain, snow, wind storms, frost or heat so as to maintain all work, materials, apparatus, and fixtures, free from injury or damage.

At the end of each day's work, all new work subject to damage by the elements and all points where water or frost may enter any part of the structure or work shall be covered.

- D. Water: General Contractor shall at all times protect excavations, trenches, and building from damage from rain water, snow, spring water, ground water backing up of drains or sewers and all other water. He shall provide all pumps and equipment enclosures required for such protection.

He shall also construct and maintain any temporary drainage necessary to direct or lead water away from the work and shall do all pumping necessary to keep excavation and lowest floor free of water at all times.

- E. Damage: All work damaged by failure to provide protection shall be removed and replaced with new work at the expense of the Contractor at fault.

## 22. Guarantee

The Contractor and/or manufacturer shall provide a minimum of one (1) year warranty for all materials and workmanship associated with the project or work performed under the Contract.

## 23. Insurance

- **Worker's Compensation**
  - State: Statutory
  - Applicable Federal (e.g., Longshoremen's): Statutory
  - Employer's Liability
    - \$500,000.00 Per Accident
    - \$500,000.00 Disease, Policy Limit
    - \$500,000.00 Disease, Each Employee
- If written under **Commercial General Liability Policy** Form
  - \$2,000,000.00 General Aggregate
  - \$1,000,000.00 Products Completed Operations Aggregate
  - \$1,000,000.00 Personal and Advertising Injury
  - \$1,000,000.00 Each Occurrence
  - \$ 50,000.00 Fire Damage (any one fire)
  - \$ 50,000.00 Medical Expense (any one person)
- **Business Automobile Liability** (including owned, non-owned and hired vehicles):
  - Bodily Injury
    - \$1,000,000.00 Per Person
    - \$1,000,000.00 Per Accident
  - Property Damage
    - \$1,000,000.00 Per Occurrence
- **Umbrella Excess Liability**
  - \$2,000,000.00 over Primary Insurance
  - \$2,000,000.00 Retention for Self-Insured Hazards Each Occurrence

A. General: The Contractor shall not commence work under the Contract until he has obtained all insurance required, and it has been approved by the Owner, nor shall Contractor allow any Subcontractor to commence work on any portion of the work until all insurance required of the Subcontractor and Sub-subcontractor has been similarly approved by the Owner.

All such insurance shall be purchased only from companies licensed and duly authorized by the Department of Insurance of the State of Illinois to do business in Illinois and to write the types of insurance policies as herein specified. Insurance companies must have a minimum policy holder's rating of A+ and a financial rating of AAAAA as stated in the latest edition of Best's Insurance Guide.

The insurance coverages must be maintained by the Contractor and the Subcontractor until all work is completed by the Contractor and accepted by the Owner. If the policy is written on claims made basis,

then the Contractor shall purchase such additional insurance as may be necessary to provide specified coverage to the District for a period of not less than five (5) years from the completion of the work.

- B. Automobile Liability: Contractor shall obtain at his expense and keep in force at all times during the performance of the work, Comprehensive Automobile Liability Insurance providing for bodily injury, personal injury and property damage, limits of an amount not less than \$500,000 per occurrence and \$1,000,000 per annual aggregate.
- C. General Liability Insurance: Contractor shall obtain at his expense and keep in force at all times during the performance of the work, Comprehensive General Liability Insurance providing for bodily injury, personal injury and property damage, limits of not less than \$1,000,000 per occurrence and \$1,000,000 annual aggregate.
- D. Worker's Compensation and Employer's Liability Insurance: Contractor shall obtain at his expense and keep in force at all times during the performance of work, worker's compensation and related insurance coverage at amounts required by statute and employer's liability with limits of not less than \$1,000,000 per occurrence.
- E. Certificates of Insurance: Within five (5) calendar days after receipt of the "Written Notice to Proceed", the Contractor shall file with the Owner, a Certificate of Insurance and Policy Endorsement showing complete coverage of all insurance required by this Section signed by the insurance companies or their authorized agents, certifying to the name and address of the party insured, the description of the work covered by such insurance, the insurance policy numbers, the limits of liability of the policies and the dates of their expirations, with a further certification from said insurance companies that their policies will not be modified, amended, changed, cancelled or terminated without thirty (30) business days prior written notice to the Owner. If any form of umbrella or excess coverage policy is utilized by the Contractor, the Owner reserves the right to require a copy of the entire policy.
- F. All policies of insurance purchased or maintained in fulfillment of this paragraph 24 shall name the Owner and Architect/Engineer as additional insureds thereunder.
- G. Failure of Owner to demand any certificate, endorsement or other evidence of full compliance with these insurance requirements or failure of Owner to identify a deficiency from evidence that is provided shall not be construed as a waiver of Contractor's obligation to maintain such insurance. The Contractor agrees that the obligation to

provide the insurance required by these documents is solely its responsibility and that this is a requirement which cannot be waived by any conduct, action, inaction or omission by the Owner.

- H. Nothing contained in the insurance requirements of the Contract Documents is to be construed as limiting the liability of the Contractor, the liability of any Subcontractor or any tier or either of their respective insurance carriers. The Owner, does not in any way, represent that the coverages or limits of insurance specified is sufficient or adequate to protect the Owner, Contractor, Architect/Engineer, or any Subcontractor's interests or liabilities but are merely at minimums. The obligation of the Contractor, the Architect/Engineer, and any Subcontractor of any tier to purchase insurance, shall not, in any way, limit their obligations to the Owner in the event the Owner should suffer an injury or loss in excess of the amount recoverable through insurance, or any loss or portion of the loss which is not covered by either the Contractors or any Subcontractor insurance.
- I. On the Certificate of Insurance, delete in the cancellation provision the following words, "Endeavor to" and "but failure to mail such notice shall impose no obligation or liability of any kind upon the company, its agents or representatives."
- J. All the insurance required of the Contractor shall state that the coverage afforded to the additional insureds shall be primary insurance of the additional insureds with respect to claims arising out of operations performed by or on their behalf. If the additional insureds@ have other insurance or self-insured coverage which is applicable to the loss, it shall be on an excess or contingent basis.
- K. All insurance required of the Contractor shall provide that any failure to comply with reporting provisions of the policies shall not affect coverage provided to the Owner or Architect/Engineer or any of their officers, directors, commissioners, officials, employees, consultants, volunteers, or agents. I. All insurance required of the Contractor shall provide that the insurance shall apply separately to each insured against whom claim is made or suit is brought, except with respect to the limits of the insurer's liability.
- L. In the event the Contractor fails to furnish and maintain the insurance required by this contract, the Owner may purchase such insurance on behalf of the Contractor, and the Contractor shall pay the cost thereof to the Owner upon demand or shall have such cost deducted from any payments due the Contractor. The Contractor agrees to furnish to the Owner the information needed to obtain such insurance.

M. In order to protect the Owner and Architect/Engineer the Contractor shall require that all its Subcontractors purchase insurance protecting the Owner and Architect/Engineer to the same extent they are protected by the insurance required herein from the Contractor.

N. Owner's Liability Insurance

1. The Contractor shall purchase and maintain insurance covering the Owner's liability for claims which may arise from operations under the Contract and that will protect the Owner and the Architect/Engineer and their agents and employees from and against all claims, damages, losses and expenses including attorney's fees arising out of or resulting from the performance of the work, provided that any such claim, damage, loss or expense (1) is attributable to bodily injury, sickness, disease or death, or to injury or to destruction of tangible property (other than the work itself) including the loss of use resulting therefrom and (2) is cause in whole or in part by any negligent act of omission of the Contractor, and Subcontractor, anyone directly or indirectly employed by any of them, or anyone for whose acts any of them may be liable, regardless of whether or not it is caused in part by a party to whom insurance is afforded pursuant to this paragraph. The minimum limits of liability purchased for such coverage shall be equal to the aggregate of the limits required for the Contractor's Liability Insurance under 24 above.
2. In any and all claims against the Owner or the Architect/Engineer or any of their agents or employees by any employee of the Contractor, any Subcontractor, anyone directly or indirectly employed by any of them, or anyone for whose acts any of them may be liable, the insurance obligation under this paragraph shall not be limited in any way by any limitation on the amount or type of damages, compensation or benefits payable by or for the Contractor or any Subcontractor under Workmen's Compensation Acts, disability benefit acts or other employee benefit acts.
3. The insurance obligations of the Contractor under this paragraph shall not extend to the liability of the Architect/Engineer, his agents or employees arising out of (1) the preparation or approval of maps, drawings, opinions, reports, surveys, change orders, designs or specifications or (2) the giving of or failure to give directions or instruction by the Architect/Engineer, his agents or employees provided that such giving or failure to give is the primary cause of the injury damage.
4. The Contractor shall provide the Owner with the Original policy and shall furnish the Architect/Engineer a memorandum copy of said policy. The named insured in the Protective Liability Policy shall be: Hoffman Estates Park District

#### 24. Indemnification

To the fullest extent permitted by law, the Contractor shall waive any right of contribution against the Owner and shall indemnify and hold harmless the Owner and the Architect/Engineer and their officers, officials, employees, volunteers and agents from and against all claims, damages losses and expenses, including, but not limited to, legal fees (attorney's and paralegal's fees, expert fees and court costs), arising out of or resulting from the performance of the Contractor's work provided that any such claim, damage, loss or expense is attributable to bodily injury, sickness, disease or death, or injury to or destruction of property, other than the work itself, including the loss of use resulting therefrom, or is attributable to misuse or improper use of trademark or copyright protected material or otherwise protected intellectual property, to the extent it is caused in whole or in part by any wrongful or negligent act or omission of the Contractor, any Subcontractor, anyone directly or indirectly employed by any of them or anyone for whose acts any of them may be liable. Such obligation shall not be construed to negate, abridge or otherwise reduce any other right to indemnity which the Owner would otherwise have. The Contractor shall similarly, protect, indemnify and hold and save harmless, the Owner, its officers, officials, employee, volunteers and agents against and from any and all claims, costs, causes, actions and expenses, including, but not limited to, legal fees, incurred by reason of Contractor's breach of any of its obligations under, or Contractor's default of any provisions of the Contract. The indemnification obligations under this paragraph shall not be limited in any way by any limitation on the amount or type of damages, compensation, or benefits payable by or for the Contractor or any subcontractor under Workers' Compensation or Disability Benefit Acts or Employee Benefit Acts

#### 25. Labor Law

The Contractor and each and every Subcontractor performing work at the site of the project to which this Contract relates shall comply with applicable and provisions of all pertinent Federal, State, and Local Labor Laws.

#### 26. Final Cleaning

Just prior to delivery of the job to the Owner, the Contractor shall perform a final cleaning of the equipment and haul away from the job site all debris created by his work on the site and surrounding area.



## 27. Time Schedule/Major Repairs

Work under the Contract shall commence within five (5) calendar days after given "Written Notice to Proceed" by Owners (or date specified) and shall continue with due diligence until due completion.

Each Contractor or Subcontractor shall and does hereby agree that he will start and prosecute his work so as to cause no delay to the Contractor and that he will complete all work under his Contract coincidentally with completion of Contractor's work.

The Contractor shall submit an estimated time schedule setting up order of procedure and time allowed for each branch of work. Contractor shall make every effort to adhere to these schedules, but reasonable modifications will be permitted from time to time to compensate for delays due to strikes or conditions beyond Contractor's control, exclusive of weather.

## 28. Avoidance of Delays (Major Repairs)

Each Contractor and Subcontractor shall be furnished a copy of the "Time Schedule" referred to above, and each shall so prosecute his work that he not only maintains his progress in accordance with the said Time Schedule but also shall cause no delays to other Contractors, either in person or through a Subcontractor, fail to maintain progress according to the approved Time Schedule or cause delay to another Contractor or Subcontractor, he shall furnish such additional labor and/or services or work such overtime as may be necessary to bring his operation up to schedule with no additional cost to Owner. Failure to maintain schedule or to the above steps to regain the agreed time schedule shall constitute default within the terms of the Contract and grounds on which the Owner may have recourse to the Contractor's Surety for remedial action.

## 29. Unit Prices and Measurement (if applicable)

Upon completion of the work, a final measurement will be conducted by the Contractor and Owner. Unit prices included in the bid proposal will be applied to the units measured to determine the final/total price of the work.

## 30. Assignment

The Contractor or any Subcontractor shall not assign the Contract nor any monies due to become due to him hereunder, to any Person, Firm, or Corporation without previous written consent of the Owner.

### 31. Extras

No extra work shall be allowed or paid for unless a Change Order is made and accepted by the Owner in writing.

### 32. Examination of Site

Before submitting proposal, contractors shall examine site. Such an examination will be presumed and no allowance will be made for extra labor or materials due to Contractor's failure to do so. Any information furnished by the Owner shall not constitute a representation concerning site conditions and the Contractor shall bear, solely and exclusively, all costs due to concealed, unknown, unusual or otherwise unforeseen conditions at the site. Contractor is aware that all such risk concerning site conditions is borne by it, has considered such in making its bid, and therefore freely waives all of its rights under the Illinois Public Construction Contract Act of 1999 .

### 33. Safety

The Contractor is responsible for the safe passage of pedestrian traffic for the duration of the job. Any precautionary measures, necessary warning signs, barricades, etc., required to inform the general public of potential hazards or dangers and as necessary to assist the Contractor in the performance of the work, shall be at his expense and provided for in his quoted price. **Public safety is a foremost concern of the Owner, therefore failure by the Contractor to take a pro-active approach to safety is unacceptable. If necessary, the Owner will take whatever steps deemed appropriate, at the cost of the Contractor, to ensure the safety of the general public and our employees.**

### 34. Personnel

If any person employed on the work site be, in the opinion of the Owner, intemperate, disorderly, incompetent, willfully negligent or dishonest in the performance of his duties, he shall be directed to cease work and vacate the job site immediately.

### 35. Liens

No payment shall become due until the Contractor, if required, shall deliver to Owner a complete release of all liens arising out of this Contract, or receipts in full in lieu thereof and, if required in either case, an affidavit that so far as he has knowledge or information, the releases and receipts include all the labor and material for which a lien could be filed. If any lien

remains unsatisfied after all payments are made, the Contractor shall refund to the Owner all monies that the latter may be compelled to pay in discharging such a lien, including all costs and a reasonable attorney's fee.

### 36. Default

In case of default by the Contractor, the Owner may procure the articles or services from other sources and hold the Contractor responsible for any excess cost occasioned thereby.

### 37. Cancellation of Contract

If the Contractor or any of his Sub-contractors shall, in the judgment of the Hoffman Estates Park District, be unable to carry on the work satisfactorily, or if the Contractor or any of his Sub-contractors shall violate any of the provisions of this contract, or in case of bankruptcy of the Contractor, or failure of the Contractor to pay for supplies or workmen, or a work-stoppage, or a failure by the Contractor to provide sufficient workmen or sufficient material for the job, the Owner may serve written notice upon the Contractor and his Surety of his intention to terminate the Contract, and, if within seven (7) days after the service of such notice, the Contractor or the Sub-contractor or the Surety have not proceeded to carry on the work in accordance with this Contract and to the satisfaction of the Owner, this Contract shall cease and terminate and the Owner shall have the right to take over the work and prosecute the same to completion by Contract for the account and at the expense of the Contractor and the Surety; and the Contractor and Surety shall be liable to the Owner for any excess costs occasioned by the Owner thereby, and in such event the Owner may take possession of and utilize in completing the work such materials, appliances, and plants as may be on the site of the work and necessary therefore; provided, however, that in the event the Owner determines that the failure of the Contractor, Sub-contractor or Surety to carry on the work in accordance with this Contract has resulted in an emergency which will require that the Owner take over the work immediately, to avoid loss or waste of a substantial part of the work already performed, the Owner may immediately take over the work and prosecute the same at the expense of the Contractor and Surety to the extent necessary to avoid damage, and may prosecute the same at the expense of the Contractor and Surety to the extent necessary to avoid damage, and may prosecute the same to completion at the expense of the Contractor and the Surety unless within seven (7) days after the services of the above described notice, the Contractor, Sub-contractor or Surety has proceeded to carry on the work in accordance with this Contract and to the satisfaction of the Hoffman Estates Park District.

38. Lien Waivers (if applicable)

Neither by partial nor final payment will the Owner be deemed to have waived any remedy for defective work or negligence on the part of the Contractor or any other portion of the Contract which, by its nature, survives after time of payment.

Supporting partial Waivers of Lien for each Subcontractor, supplier and prime contractor must accompany each request for progress payment.

Waivers must spell out exact description of work performed for which Waiver is issued and state whether dollar amount is full amount received or amount of work less retainage, held by prime contractor.

For final payment it is necessary to submit final waivers in the full amount of the Contracts for all Subcontractors, suppliers and prime contractors.

Waivers must be accompanied by a sworn statement listing Subcontractors and suppliers, the amount of their Contracts and the amount requested.

39. Line and Grade Stakes (if applicable)

Stakes for lines and grades shall be provided once by the Engineer. Costs for replacement of damaged stakes shall be paid by the Contractor. Prior to commencing work and before pouring or finally adjusting any structure or closing any excavation, the Contractor shall verify the correctness of any grades so as to conform to the Contract Documents.

40. Construction Observation

A Consultant may be called upon to observe the work on behalf of the Owner and will provide general assistance during construction insofar as proper interpretation of the Contract Documents is affected. The consultant shall not be responsible for the acts or omissions of the Contractor's superintendent or other employees.

All materials used and all completed work by the Contractor shall be subject to the observation of the Owner/Owner's representative. The Contractor shall furnish such samples of materials for examination and tests as may be requested by the Owner and shall furnish any information required concerning the nature or source of any materials or equipment, which he proposes to use. Any material, equipment, or work which does not satisfactorily meet the Contract Documents may be rejected by the Owner by giving written notice to the Contractor. All rejected materials,

equipment, or work shall be promptly removed and replaced at the Contractor's expense.

#### 41. Field Representatives

Field representatives may be appointed by the Owner, Architect or Engineer to see that the work is performed in accordance with the Contract Documents. Field representatives shall have the authority to condemn and/or reject defective work materials. Only the Owner shall have authority to suspend work. Field representatives shall have no authority to permit deviation from the Contract Documents and Owner, the Contractor shall be liable for any deviations made without a written order from the Engineer.

## HOFFMAN ESTATES PARK DISTRICT

### CONSTRUCTION SPECIFICATION FOR CHAIN LINK FENCE, COMMERCIAL, COMMERCIAL VINYL COLOR COATED

#### PART 1 – GENERAL

##### 1.01 WORK INCLUDED

The contractor shall provide all labor, materials and appurtenances necessary for installation of the color chain link fencing system.

##### 1.02 RELATED WORK

Section 02500 – Paving and Surfacing

Section 03300 – Case-In-Place Concrete

Section 04200 – Unit Masonry

##### 1.03 SYSTEM DESCRIPTION

The contractor shall supply a total color chain link fencing system of the design, style and strength defined herein. The system shall include all components (i.e., framework, chain link fabric, gates and fittings) required.

##### 1.04 QUALITY ASSURANCE

The contractor shall provide laborers and supervisors who are thoroughly familiar with the type of construction involved and materials and techniques specified.

##### 1.05 REFERENCES

A. American Society for Testing and Materials (ASTM) Standards: A90/A90M - Test Method for Weight (Mass) of Coating on Iron and Steel Articles with Zinc or Zinc-Alloy Coatings. A653/A653M - Specification for Steel Sheet, Zinc-Coated (Galvanized) or Zinc-Iron Alloy-Coated (Galvannealed) by the Hot-Dip Process. A924/A924M - Specification for General Requirements for Steel Sheet, Metallic-Coated by the Hot-Dip Process. B6 - Specification for Zinc. B117 - Practice for Operating Salt Spray (Fog) Apparatus. D1499 - Practice for Operating Light- and Water-Exposure Apparatus (Carbon-Arc Type) for Exposure of Plastics. D3359 - Test Methods for Measuring Adhesion by Tape Test. E8/E8M - Test Methods for Tension Testing of Metallic Materials. F567 - Practice for Installation of Chain-Link Fence. F626 - Specification for Fence Fittings. F668 - Specification for Poly (Vinyl Chloride) (PVC)-Coated Steel Chain-Link Fence Fabric. F900 - Specification for Industrial and Commercial Swing Gates. F934 - Specification for Standard Colors for Polymer-Coated Chain Link Fence Materials. F969 - Practice for Construction of Chain-Link Tennis Court Fence. F1043 - Specification for Strength and Protective Coatings on Metal Industrial Chain Link Fence Framework. F1184 - Specification for Industrial and Commercial Horizontal Slide Gates.

**B.** American Association of State Highway and Transportation Officials (AASHTO) Standards: M181 - Standard Specification for Chain-Link Fence.

**C.** United States Federal Supply Service General Services Administration Specifications: RR-F-191/3 - Federal Specification Sheet for Fencing, Wire and Post, Metal (Chain-Link Fence Posts, Top Rails and Braces) - Detail Specification.

#### **1.06 SUBMITTAL**

The manufacturer's literature shall be submitted prior to installation.

#### **1.07 PRODUCT HANDLING AND STORAGE**

Upon receipt at the job site, all materials shall be checked to ensure that no damages occurred during shipping or handling. Materials shall be stored in such a manner to ensure proper ventilation and drainage and to protect against damage, weather, vandalism and theft.

### **PART 2 - MATERIALS**

#### **2.01 MANUFACTURER**

Framework for color chain link fence systems shall conform to Ameristar® PermaCoat® PC-20™ Fence Pipe (commercial weight), as manufactured by Ameristar® Fence Products in Tulsa, Oklahoma.

#### **2.02 MATERIAL – STEEL FRAMEWORK**

**A.** The steel material used to manufacture Ameristar® PermaCoat® PC-20™ Fence Pipe shall be zinc-coated steel strip, galvanized by the hot-dip process conforming to the criteria of ASTM A653/A653M and the general requirements of ASTM A924/A924M.

**B.** The zinc used in the galvanizing process shall conform to ASTM B6. Weight of zinc shall be determined using the test method described in ASTM A90 and shall conform to the weight range allowance for ASTM A653, Designation G-90.

**C.** The framework shall be manufactured in accordance with commercial standards to meet the strength (50,000 psi minimum yield strength) and coating requirements of ASTM F1043, Group IC, Electrical Resistance Welded Round Steel Pipe, light industrial weight.

**D.** The exterior surface of the electrical resistance weld shall be recoated with the same type of material and thickness as the basic zinc coating.

**E.** The manufactured framework shall be subjected to the PermaCoat® process, a complete thermal stratification coating process (multi-stage, high-temperature, multi-

layer) including, as a minimum, a six-stage pretreatment/wash (with zinc phosphate), an electrostatic spray application of an epoxy base, and a separate electrostatic spray application of a polyester finish.

**F.** The material used for the base coat shall be a (gray color) thermosetting epoxy; the minimum thickness of the base coat shall be two (2) mils. The material used for the finish coat shall be a thermosetting “no-mar” TGIC polyester powder; the minimum thickness of the finish coat shall be two (2) mils. The stratification coated pipe shall demonstrate the ability to endure a salt-spray resistance test in accordance with ASTM B117 without loss of adhesion for a minimum exposure time of 3,500 hours. Additionally, the coated pipe shall demonstrate the ability to withstand exposure in a weather-ometer apparatus for 1,000 hours without failure in accordance with ASTM D1499 and to show satisfactory adhesion when subjected to the cross-hatch test, Method B, in ASTM D3359. The polyester finish coat shall not crack, blister or split under normal use.

**G.** The color of all framework shall be **Black** in accordance with ASTM F934.

**H.** The strength of Fence Pipe shall conform to the requirements of ASTM F1043; the minimum weight shall not be less than 90% of the nominal weight. The strength of line, end, corner and pull posts shall be determined by the use of 4’ or 6’ cantilevered beam test. The top rail shall be determined by a 10’ free-supported beam test. An alternative method of determining pipe strength is by the calculation of bending moment. Conformance with this specification can be demonstrated by measuring the yield strength of a randomly selected piece of pipe from each lot and calculating the section modulus. The yield strength shall be determined according to the methods described in ASTM E8. For materials under this specification, the 0.2 offset method shall be used in determining yield strength. Terminal posts, line posts and top/bottom rails shall be precut to specified lengths.

### **2.03 MATERIAL – FENCE FABRIC**

**A.** The material for chain link fence fabric shall be manufactured from galvanized steel wire. The weight of zinc shall meet the requirements of ASTM F668, Table 4. Galvanized wire shall be PVC-coated to meet the requirements of ASTM F668. The class of the fence fabric shall be 2” x 2” **BLACK VINYL CHAIN LINK FABRIC 6 GAUGE STEEL CORE FUSE AND BONDED 5 GAUGE FINISH.**

**B.** Selvage: Top edge **Knuckled** and bottom edge **Knuckled.**

**C.** Color: The coating color for the fence fabric shall be **Black.** Reference ASTM F668 and ASTM F934.

**D.** Wire Size: The size of the steel wire core shall be **Black vinyl with a 6 Gauge Steel core and fused bonded with a 5 gauge finish.**



**E. Height and Mesh Size:** The fabric height shall be **4 ft** high as noted on plan with a mesh size of **2** inches.

#### **2.04 MATERIAL – FENCE FITTINGS**

The material for fence fittings shall be manufactured to meet the requirements of ASTM F626. The coating for all fittings shall be the same PermaCoat® color coating system required for the framework (see 2.02); the color of all fittings and fasteners shall be **Black** in accordance with ASTM F934. All fasteners shall be stainless steel.

#### **2.05 MATERIAL – GATES**

Swing gates shall be manufactured and coated to meet the requirements of ASTM F900. Slide gates shall be manufactured to meet the requirements of ASTM F1184. The color of all gates shall be **Black** in accordance with ASTM F934.

#### **2.06 PIPE SIZING**

All gates and end posts on 10 foot high fence shall be 3 inch pipe. All Line Posts on 10 foot high fence shall be 2 inch diameter pipe. Top, middle and bottom rail shall be 1 5/8 inch diameter pipe. All posts on 4 foot high fence shall be 2 inches diameter pipe. Top and bottom rail on 4 foot high fence shall be 1 5/8 inch diameter pipe.

### **PART 3 – EXECUTION**

#### **3.01 PREPARATION**

All new installation shall be laid out by the contractor in accordance with the construction plan.

#### **3.02 INSTALLATION**

Install chain link fence in accordance with ASTM F567. For chain link tennis court fences, install in accordance with ASTM F969. Fence posts shall be set at spacings of a maximum of 10' o.c. Gate posts shall be spaced according to the gate openings specified in the construction plans. The "Paving and Surfacing," sections of this specification shall govern post base placement and material requirements. Install fabric on security side and attach with wire ties or clip to line posts at 15 inches o.c. and to rails, braces and tension wire at 24 inches o.c. All concrete footing piers shall be dug to a depth no less than 42 inches below finish grade. Finish grade shall be the lowest elevation within five foot of the post hole locator.

#### **3.03 CLEANING**

The contractor shall clean the jobsite of excess materials. Post hole excavations shall be scattered uniformly away from posts.

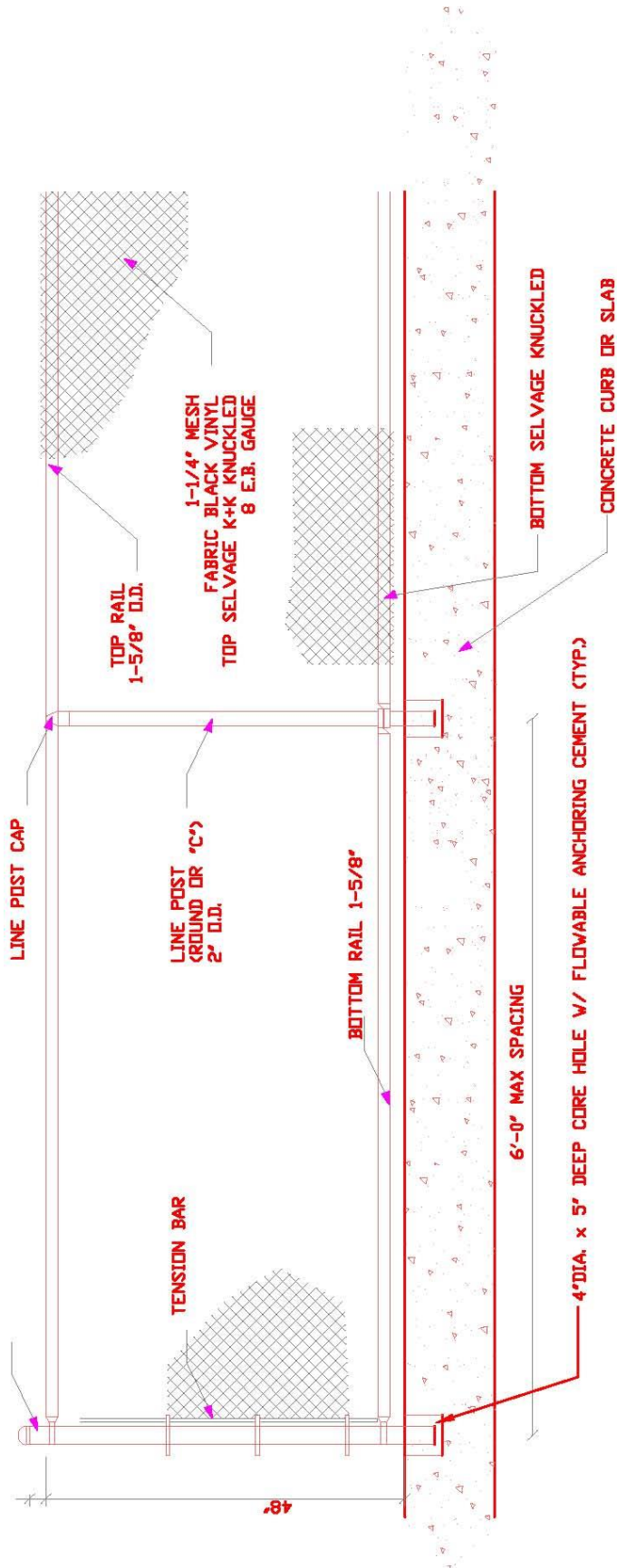

**CORED CHAIN LINK PLAYGROUND SAFETY FENCE DETAIL**

**HOFFMAN ESTATES PARK DISTRICT  
CONSTRUCTION SPECIFICATION FOR ALUMINUM ORNAMENTAL FENCING**

**PART 1 – GENERAL**

**1.01 SECTION INCLUDES**

- A. Decorative aluminum fencing, gates and accessories

**1.02 RELATED SECTIONS**

- A. Section – Earthwork
- B. Section – Concrete

**1.03 SYSTEM DESCRIPTION**

- A. The manufacturer shall supply a total ornamental aluminum fence systems of the style, strength, size and color defined herein. The system shall include all components (pickets, posts, rails, gates, hardware, and accessories) as required, and shall be fabricated, coated, and assembled in the United States.

**1.04 QUALITY ASSURANCE**

- A. The contractor shall provide laborers and supervisors who are familiar with the type of construction involved, and the materials and techniques specified.
- B. Manufacturer of fence systems must have ten (10) years of documented experience in manufacturing the products specified in this section.

**1.05 REFERENCES**

- A. AAMA 2604 – Voluntary Specification, Performance Requirements and Test Procedures for High Performance Organic Coatings on Aluminum Extrusions and Panels
- B. AAMA 2603 – Voluntary Specifications, Performance Requirements and Test Procedures for Pigmented Organic Coatings on Aluminum Extrusions and Panels.
- C. ASTM B117 – Practice for Operating Salt Spray (Fog) Apparatus
- D. ASTM D2247 – Standard Practice for Testing Water Resistance of Coatings in 100% Relative Humidity.
- E. ASTM B221- Specification for Aluminum Alloy Extruded Bars, Shapes, and Tubes
- F. ASTM B85 – Standard Specification for Aluminum-Alloy Die Castings

## **1.06 SUBMITTALS**

- A. Manufacturer's submittal package shall be provided prior to installation.
- B. Changes in specification may not be made after the bid date.
- C. Samples of assembled materials, components, hardware, accessories, and/or colors, if requested.

## **1.07 PRODUCT DELIVERY, STORAGE, AND HANDLING**

- A. Upon receipt, materials should be checked for damage that may have occurred in shipping to the job site
- B. Each package shall bear the name of the manufacturer
- C. Store products in manufacturer's unopened packaging
- D. Store materials in a secure and dry area to protect against damage, weather, vandalism and theft.
- E. Transport, handle and store products with care to protect against damage before installation.

## **PART 2 – PRODUCTS**

### **2.01 MANUFACTURER COMMERCIAL/INDUSTRIAL GRADE**

- A. The fencing system shall be Aluminum Fence as manufactured by Jerith Manufacturing Co., Inc., telephone 800-344-2242, fax 215-676-9756, email [sales@jerith.com](mailto:sales@jerith.com) or approved equal
- B. Nominal fence height 48 inches
- C. Color shall be Black

### **2.02 MATERIALS**

- A. Aluminum Extrusions: All posts and rails used in the fence system shall be extruded from HS-35™ aluminum alloy having a minimum yield strength of 35,000 psi. All pickets shall have a minimum yield strength of 25,000 psi. 6063-TS and 6063-T52 Alloys (in accordance with ASTM B221) are not acceptable for any components.
- B. Fasteners: All fasteners shall be stainless steel. Hidden spring clips shall be used to connect the pickets to the horizontal rails. Rail to post connections shall be made using stainless steel inserts that are hidden inside the horizontal rails.
- C. Accessories: Aluminum sand and die casting shall be used for all scrolls, post caps, finials, and miscellaneous hardware. Die castings shall be made from Alloy A360.0 as per ASTM B85 for superior corrosion resistance. Alloy A380.0 is not acceptable.

**D. Material Strength/Thickness:**

Industrial Strength

1" sq. x .062" thick

1 5/8" x .070" thick

1 5/8" x .100" thick

2 1/2" sq. x .075" thick

4" sq. x .125" thick

6" sq. x .125" thick

**2.03 FINISH**

- A. Pretreatment:** A three stage non-chrome pretreatment shall be applied. The first step shall be a chemical cleaning, followed by a water rinse. The final stage shall be a dry-in-place activator which produces a uniform chemical conversion coating for superior adhesion.
- B. Coating:** Fence materials shall be coated with FencCoat™ and shall have a cured film thickness of at least 2.0 mils.
- C. Tests:** The cured finish shall meet or exceed AAMA 2604, which includes the following requirements:
  - 1. Humidity resistance of 3,000 hours using ASTM D2247
  - 2. Salt-spray resistance of 3,000 hours using ASTM B117.
  - 3. Outdoor weathering shall show no adhesions loss, checking or crazing, with only slight fade and chalk when exposed for 5 years in Florida facing south at a 45 degree angle.

**2.04 FABRICATION**

- A.** Horizontal rails shall be 1" x 1 1/2" channels formed in a modified "U" shape. Pickets shall pass through holes punched in the top of the rail. The top wall shall be .55" thick and the side walls .082" thick for superior vertical load strength. There shall be two horizontal rails in each section.
- B.** Pickets shall be fastened to the rails using stainless steel spring clips that are hidden inside the rails. Pickets shall be 1" square and have a wall thickness of .050". Plastic clips and screws, whether hidden or visible, are not acceptable. Welding the pickets to the rails is not permitted. Spacing between pickets shall not exceed 3".
- C.** Posts shall be 2 1/2" square extrusions with pre-punched holes which allow for fence section rails to slide in. Posts shall be spaced 72 1/2" on center and have .060" walls. Gate posts shall be 4" square with .125" walls and used on both sides of a gate. Die cast aluminum caps shall be provided with all posts.
- D.** Gates shall have welded frames and shall support a 250 lb. vertical load on the latch side of the gate without collapsing. Walk gates shall be self-closing and self-latching.

- E. Assembled sections shall support a 350 lb. vertical load at the midpoint of any horizontal rail.

## **2.05 WARRANTY**

- A. The entire fence system shall have a written Limited Lifetime Warranty against rust and defects in workmanship and materials. In addition, the FencCoat finish shall be warranted not to crack, chip, peel, or blister for the same period.

## **PART 3 – EXECUTION:**

### **3.01 PREPARATION**

- A. Verify areas to receive fencing are completed to final grades and elevations.
- B. Ensure property lines and legal boundaries are clearly established.
- C. Remove any surface irregularities which may cause interference with the installation of the aluminum fence.

### **3.02 FENCE INSTALLATION**

- A. Install fence in accordance with the manufacturer's instructions.
- B. Contractor to core a 4" diameter hole no less than 6" deep into existing concrete.
- C. Insert 2 1/2" square fence post no less than 5" into cored hole, plumb and grout with non-shrinking hydraulic cement. The fence posts shall be set no further than 72 1/2" on centers. Minimum spacing between posts shall be four feet.
- D. Slide stainless steel inserts in the horizontal rails, then push the ends of the rails into the pre-punched holes in post to fasten in place.
- E. Center and align posts in holes to required depth. Place concrete around posts and tamp for consolidation. After tamping, check alignment of posts and make necessary corrections before the concrete hardens.

### **3.03 GATE INSTALLATION**

- A. Set gate posts plum and level for gate openings specified in construction drawings.
- B. Install gates to allow full opening without interference after concrete has hardened around gate posts. Adjust hardware for smooth operation. Install one drop rod for double gates.

### **3.04 ACCESSORIES**

- A. Install post caps and other accessories to complete fence.

### **3.05 CLEANING**

- A.** Contractor shall clean site of debris and excess materials. Post hole excavations shall be scattered uniformly away from posts.
- B.** If necessary, clean fence system with mild household detergent and clean water. Excess concrete must be removed from posts and other fencing material before it hardens.

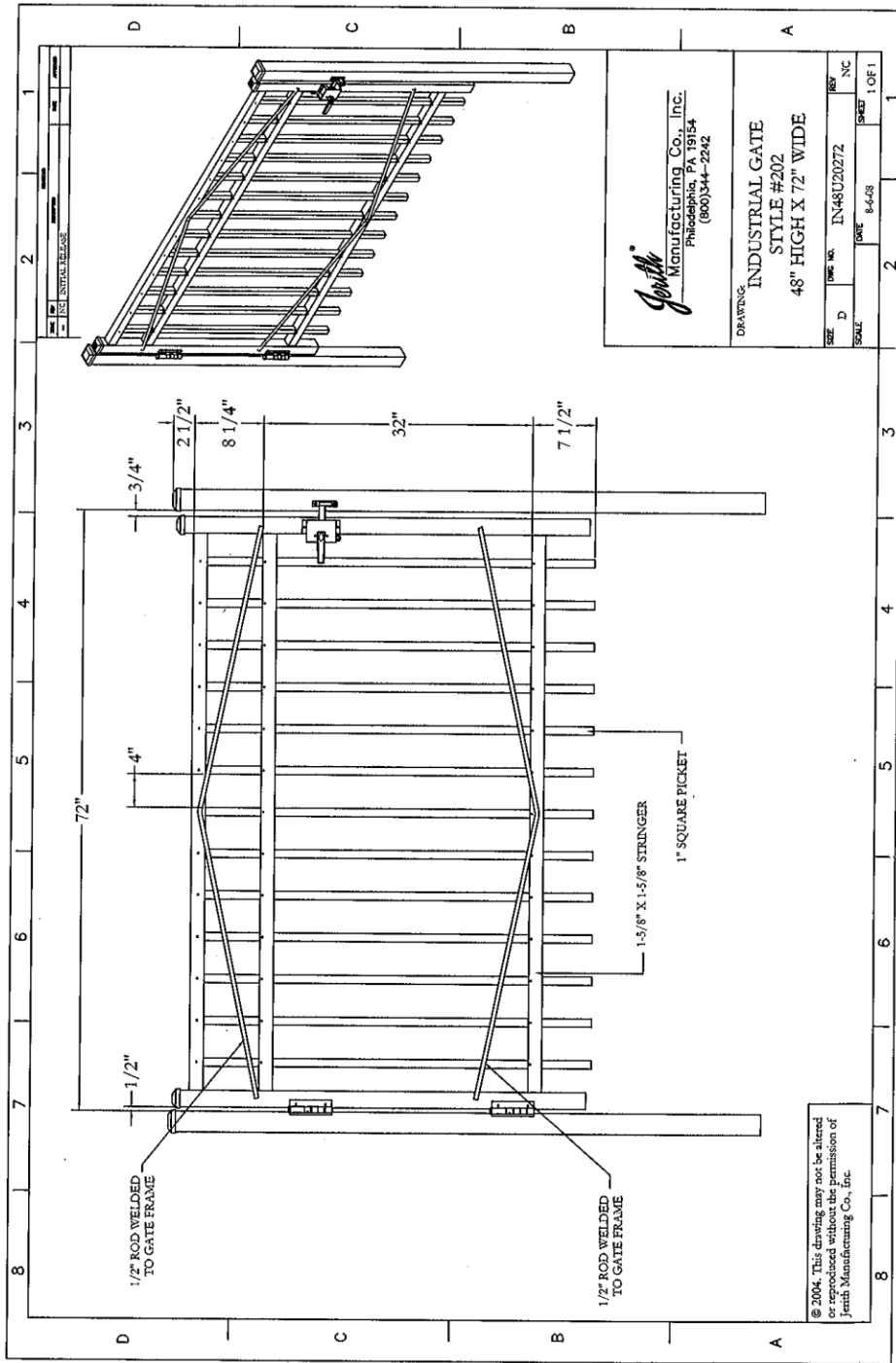

**PARK PLAYGROUND ORNAMENTAL FENCE**



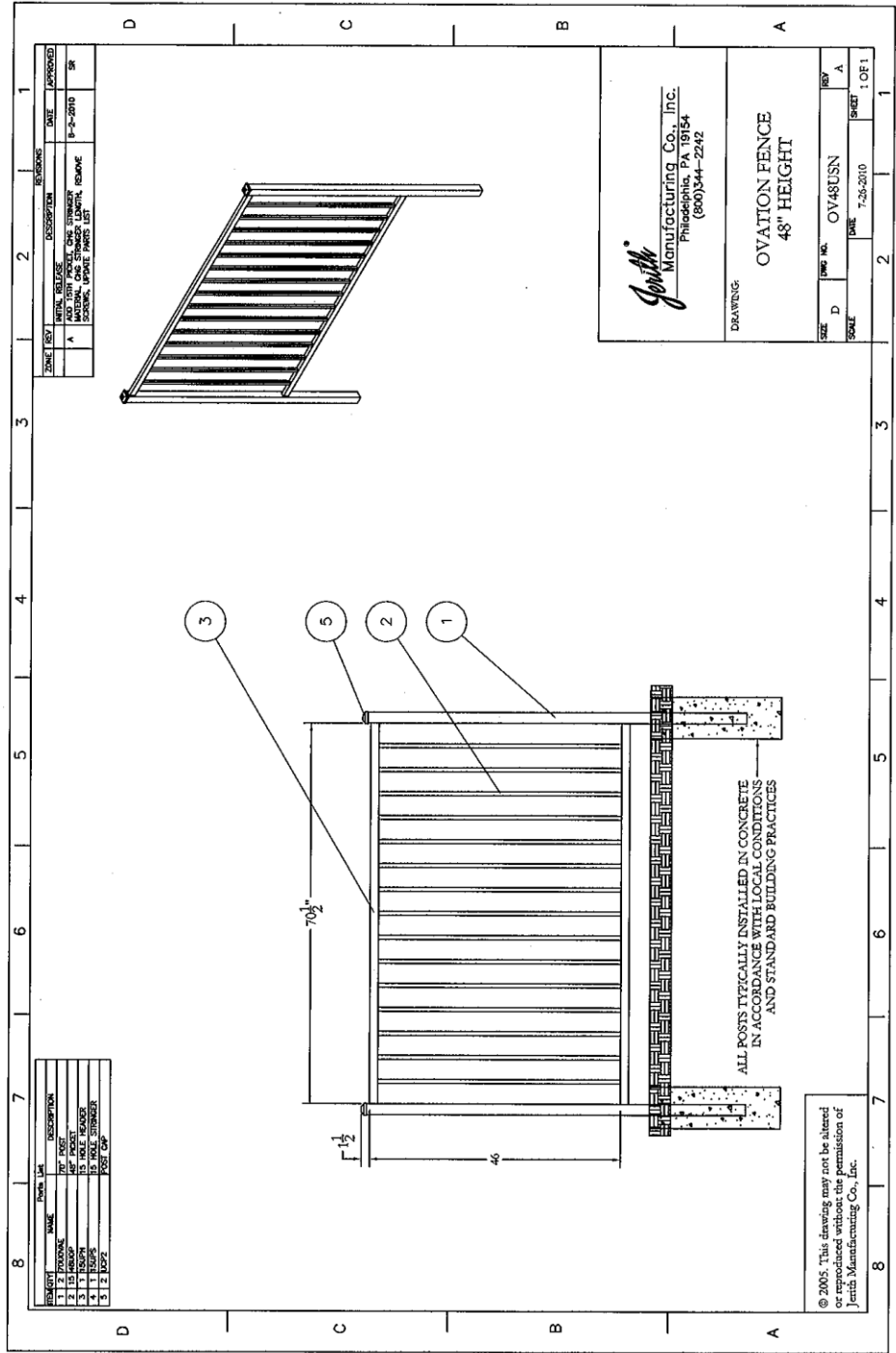

ZONE	REV	DESCRIPTION	DATE	APPROVED
A	1	INITIAL RELEASE	8-2-2010	SR
		MODIFY ONE STAKE TO MATCH LAYOUT REMOVE SCREWS, UPDATE PARTS LIST		

REV	DATE	DESCRIPTION
1	7/20/06	1" POST
2	1/5/08	1" POST
3	1/5/08	1" POST
4	1/5/08	1" POST
5	1/5/08	1" POST

**Jenith**  
 Manufacturing Co., Inc.  
 Philadelphia, PA 19154  
 (800)344-2242

DRAWING:  
**OVATION FENCE**  
**48" HEIGHT**

SIZE	D	DATE	7-26-2010	SHEET	1 OF 1
SCALE					

© 2005. This drawing may not be altered or reproduced without the permission of Jenith Manufacturing Co., Inc.

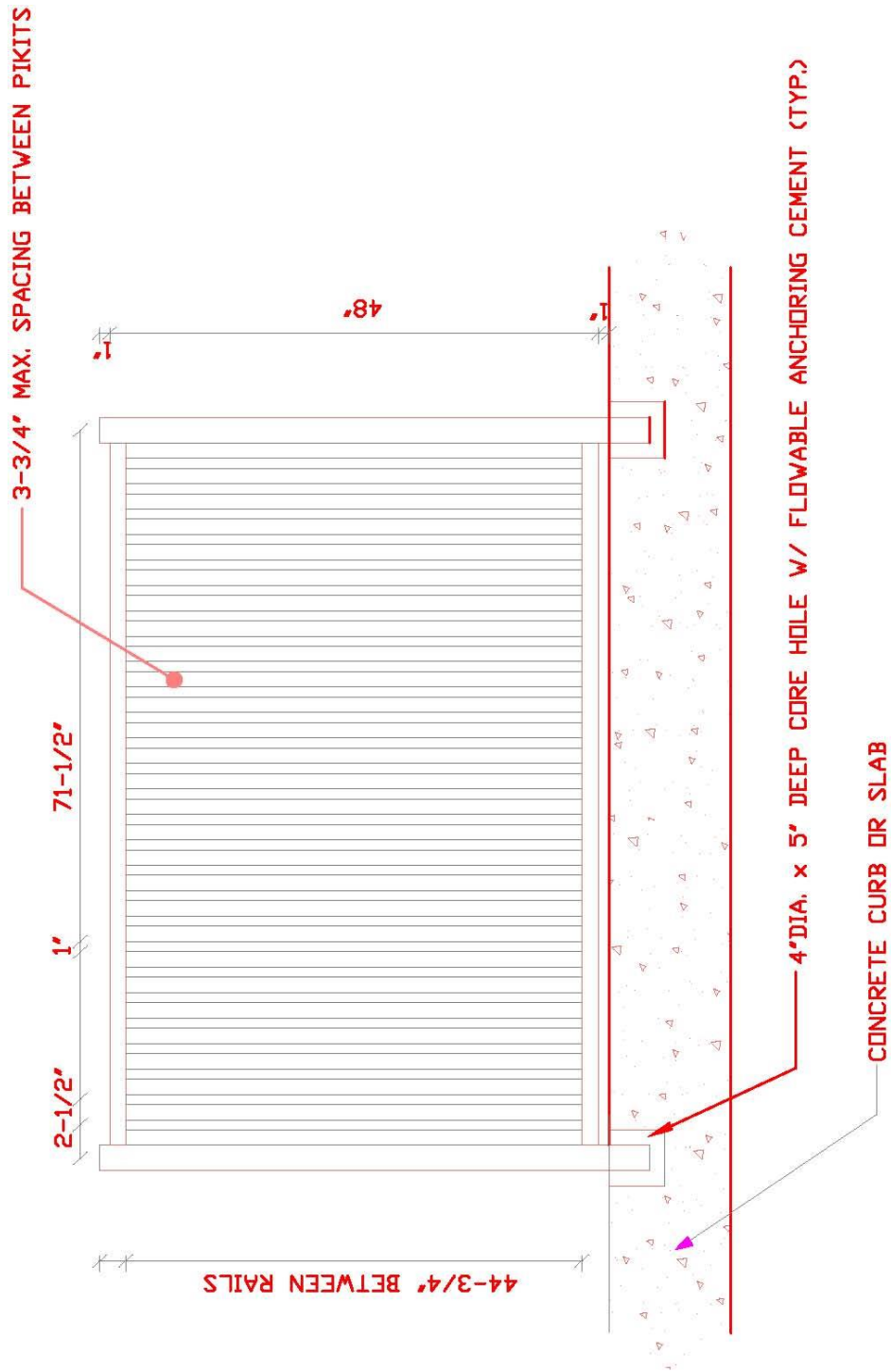

## ORNAMENTAL PLAYGROUND SAFETY FENCE DETAIL

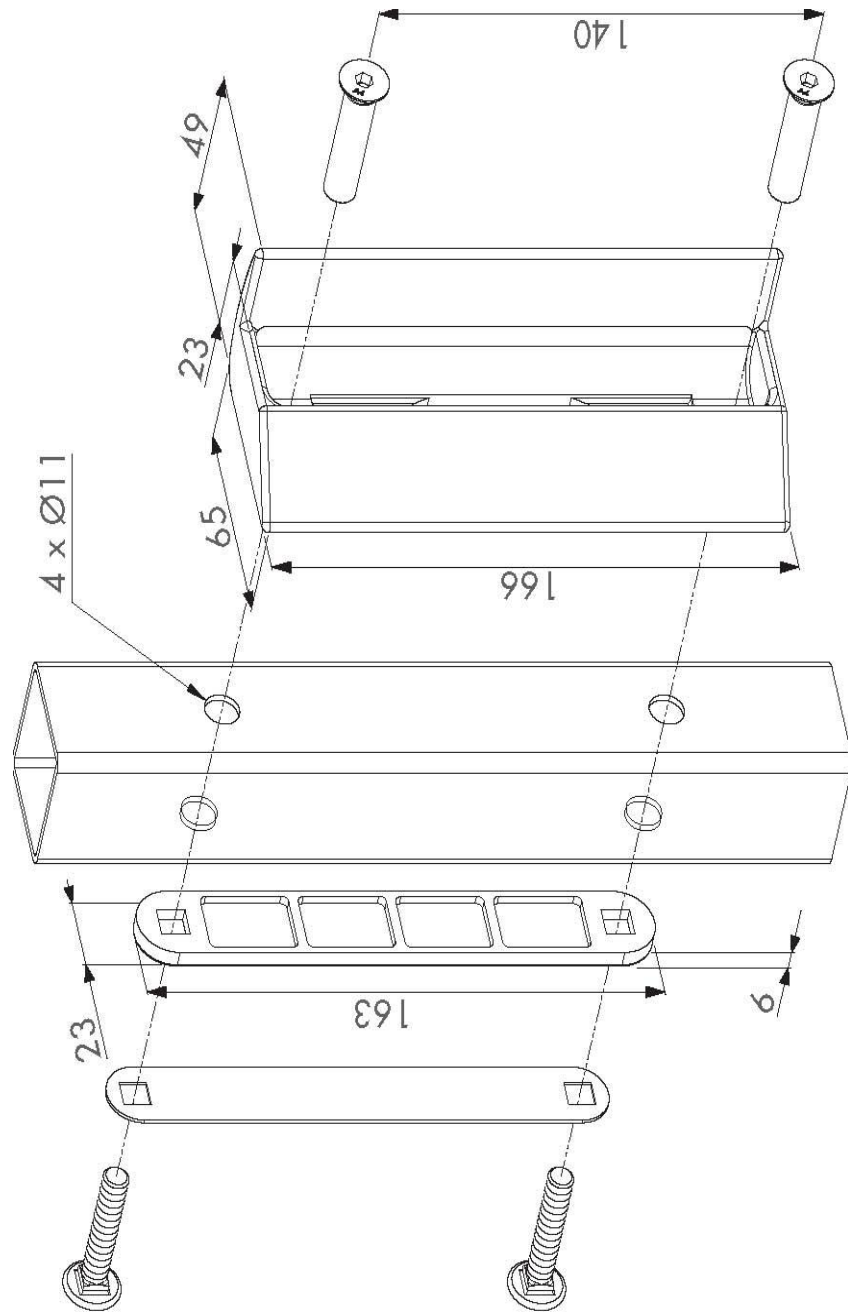

## GATE RECEIVER